



CLASSIC PREMIUM PRESTIGE



EN

ASSEMBLY INSTRUCTIONS

Important: Read the entire instruction before starting the assembly. Strictly follow all the instructions provided in this manual and carry out all of the stages of the installation process in the specified order. Failure to comply with these rules may lead to incorrect fitting of the decorative laths and the occurrence of visual defects. The warranty certificate is void if it is found that damage has been caused by incorrect installation. The base on which the product is to be installed must be flat and without significant differences in level. The product must be attached to the base. Note: Use lube for all screws to prevent them from breaking. Make sure that the greenhouse pallet cannot tip over and cause accidents. Make sure that the ground where you put the pallet is in level. Installing two ground spikes to the pallet will prevent it from tipping. Do not remove all the wooden rules inside the pallet. Only remove the ones that are necessary to access the part you need.

Installation requires at least 2 people.

DK

MONTERINGSVEJLEDNING

Vigtigt: Læs hele vejledningen, før du begynder monteringen. Følg nøje alle instruktioner i denne manual og udfør alle trin i installationsprocessen i den angivne rækkefølge. Manglende overholdelse af disse regler kan føre til forkert montering af de dekorative lister og visuelle fejl. Garantibeviset er ugyldigt, hvis det konstateres, at skader er forårsaget af forkert installation. Basen, hvor produktet skal installeres, skal være flad og uden væsentlige niveauforskelle. Produktet skal fastgøres til basen. Bemærk: Brug smøremiddel på alle skruer for at forhindre, at de knækker. Sørg for, at drivhusets palle ikke kan vælte og forårsage ulykker. Sørg for, at jorden, hvor du placerer pallen, er i vater. Installation af to jordspyd i pallen forhindrer den i at vælte. Fjern ikke alle trælistene inde i pallen. Fjern kun de nødvendige for at få adgang til de dele, du har brug for.

Installationen kræver mindst 2 personer.

FR

INSTRUCTIONS D'ASSEMBLAGE

Important: Lisez entièrement ces instructions avant de commencer l'assemblage. Suivez strictement toutes les indications de ce manuel et réalisez toutes les étapes du processus d'installation dans l'ordre spécifié. Le non-respect de ces règles peut entraîner une mauvaise fixation des éléments décoratifs et des défauts visuels. Le certificat de garantie est annulé en cas de dommages dus à une mauvaise installation. La base sur laquelle le produit doit être installé doit être plane et sans différences de niveau significatives. Le produit doit être fixé à la base. Remarque : Utilisez du lubrifiant sur toutes les vis pour éviter qu'elles ne se cassent. Assurez-vous que la palette de la serre ne puisse pas basculer et provoquer d'accidents. Vérifiez que le sol sur lequel vous placez la palette est bien nivelé. L'installation de deux piquets de sol sur la palette empêchera son basculement. Ne retirez pas toutes les pièces en bois à l'intérieur de la palette, mais seulement celles nécessaires pour accéder aux éléments requis.

L'installation nécessite au moins 2 personnes.

SE

MONTERINGSANVISNING

Viktigt: Läs hela instruktionen innan du påbörjar monteringen. Följ noggrant alla instruktioner i denna manual och genomför alla steg i installationsprocessen i den angivna ordningen. Underlåtenhet att följa dessa regler kan leda till felaktig montering av de dekorativa listerna och orsaka visuella defekter. Garantibeviset är ogiltigt om det visar sig att skadan orsakats av felaktig installation. Basen som produkten ska installeras på måste vara plan och utan betydande nivåskillnader. Produktet måste fästas i basen. Notera: Använd smörjmedel för alla skruvar för att förhindra att de går sönder. Se till att växthusets pall inte kan välta och orsaka olyckor. Se till att markstråvor i pallen förhindrar att den tippar. Ta inte bort alla träreglar inuti pallen. Ta bara bort de som är nödvändiga för att komma åt den del du behöver.

Installation kräver minst 2 personer.

FI

ASENNUSOHJEET

Tärkeää: Lue koko ohje ennen asennuksen aloittamista. Noudata tarkasti kaikkia tämän ohjekirjan ohjeita ja suorita kaikki asennusvaiheet määrättyssä järjestyksessä. Näiden sääntöjen noudattamatta jättäminen voi johtaa koristeosien virheelliseen kiinnitykseen ja visuaalisiin virheisiin. Takuu mitätöidään, jos havaitaan, että vahinko on aiheutunut virheellisestä asennuksesta. Tuotteen asennusohje on oltava tasainen ja ilman merkittäviä korkeuseroja. Tuote on kiinnitettävä alustaan. Huomio: Käytä voiteluainetta kaikissa ruuveissa estääksesi niiden katkeamisen. Varmista, ettei kasvihooneen lava voi kaatua ja aiheuttaa onnettomuuksia. Varmista, että alusta, jolle lava asetetaan, on tasainen. Kaksi maapiikkiä lavassa estää sen kaatumisen. Älä poista kaikkia puisia tukia lavasta. Poista vain ne, jotka ovat tarpeen osien saavuttamiseksi.

Asennukseen tarvitaan vähintään 2 henkilöä.

LV

MONTĀŽAS INSTRUKCIJA

Svarīgi: Pirms montāžas sāksanas rūpīgi izlasiet visu instrukciju. Stingri ievērojiet visus šajā rokasgrāmatā sniegtos norādījumus un veiciet visas uzstādīšanas darbības norādītā secībā. Neievērojot šos noteikumus, var rasties dekoratīvo listu nepareiza montāža un vizuāli defekti. Garantijas sertifikāts tiek anulēts, ja tiek konstatēts, ka bojājumi radušies nepareizas uzstādīšanas dēļ. Pamatnei, uz kuras produkts tiek uzstādīts, jābūt līdzenai un bez būtiskām līmeņa atšķirībām. Produkts ir jāpiestiprina pie pamatnes. Piezīme: Lietojiet smērvielu visām skrūvēm, lai novērstu to lūšanu. Pārļiecinieties, ka siltumnīcas palete nevar apgāzties un izraisīt negadījumus. Pārļiecinieties, ka virsma, kurā palete tiek novietota, ir līmenī. Divu zemes mietu uzstādīšana paletei novērsīs tās apgāšanos. Neizņemiet visas koka daļas no paletes, tikai tās, kas nepieciešamas, lai piekļūtu vajadzīgajām detaļām.

Uzstādīšanai nepieciešami vismaz 2 cilvēki.

NO

MONTERINGSINSTRUKSJONER

Viktig: Les hele instruksjonen før du starter monteringen. Følg nøye alle instruksjonene i denne manualen og utfør alle trinnene i installasjonsprosessen i den angitte rekkefølgen. Unnlattelse av å følge disse reglene kan føre til feilmontering av de dekorative listene og forekomsten av visuelle defekter. Garantibeviset er ugyldig hvis det viser seg at skader er forårsaket av feil installasjon. Grunnlaget som produktet skal installeres på, må være flatt og uten vesentlige nivåforskjeller. Produktet må festes til basen. Merk: Bruk smøremiddel på alle skruer for å unngå at de knekker. Sørg for at veksthusets pall ikke kan velte og forårsake ulykker. Sørg for at bakken der du plasserer pallen, er i vater. Å installere to jordspiker i pallen forhindrer at den velter. Ikke fjern alle trerammene inne i pallen. Fjern kun de som er nødvendige for å få tilgang til delen du trenger.

Installasjon krever minst 2 personer.

DE

MONTAGEANLEITUNG

Wichtig: Lesen Sie die gesamte Anleitung, bevor Sie mit der Montage beginnen. Befolgen Sie strikt alle Anweisungen in diesem Handbuch und führen Sie alle Installationsschritte in der angegebenen Reihenfolge aus. Die Nichtbeachtung dieser Regeln kann zu einer fehlerhaften Befestigung der Zierleisten und optischen Mängeln führen. Die Garantiebescheinigung erlischt, wenn festgestellt wird, dass Schäden durch unsachgemäße Installation verursacht wurden. Die Basis, auf der das Produkt installiert wird, muss eben und ohne erhebliche Höhenunterschiede sein. Das Produkt muss an der Basis befestigt werden. Hinweis: Verwenden Sie Schmiermittel für alle Schrauben, um Brüche zu vermeiden. Stellen Sie sicher, dass die Palette des Gewächshauses nicht umkippen und Unfälle verursachen kann. Achten Sie darauf, dass der Boden, auf dem die Palette steht, eben ist. Die Installation von zwei Bodenankern verhindert das Umkippen der Palette. Entfernen Sie nicht alle Holzstützen in der Palette. Entfernen Sie nur die, die zum Zugriff auf die benötigten Teile erforderlich sind.

Für die Installation sind mindestens 2 Personen erforderlich.

EE

PAIGALDUSJUHEND

Oluline: Lugege kogu juhend enne paigalduse alustamist läbi. Järgige rangelt kõiki käesolevas juhendis toodud juhiseid ning täitke kõik paigaldusetapid ettenähtud järjekorras. Nende reeglite eiramine võib põhjustada dekoratiivliistude valet kinnitamist ja visuaalseid defekte. Garantii kehtivus lõpeb, kui tuvastatakse, et kahjustused on põhjustatud valest paigaldusest. Toote paigaldusalus peab olema tasane ja ilma oluliste kõrguse erinevusteta. Toode tuleb alusele kinnitada. Märkus: Kasutage kõigi kruvide määrimiseks määrdeainet, et vältida nende purunemist. Veenduge, et kasvuhoonealus ei saaks ümber kukkuda ja õnnetusi põhjustada. Kontrollige, et pind, kuhu alus asetatakse, oleks tasane. Kahe maapinnaankru paigaldamine alusele aitab vältida selle ümberkukkumist. Ärge eemaldage kõiki puitelemente alusest, vaid ainult need, mis on vajalikud juurdepääsuks vajalikele osadele.

Paigaldamiseks on vaja vähemalt 2 inimest.

LT

MONTAVIMO INSTRUKCIJA

Svarbu: Prieš pradėdami montavimą atidžiai perskaitykite visą instrukciją. Griežtai laikykitės visų šiame vadove pateiktų nurodymų ir vykdykite visus įrengimo etapus nurodyta tvarka. Nesilaikant šių taisyklių, dekoratyvinės juostelės gali būti neteisingai sumontuotos, o vizualiniai defektai – neišvengiami. Garantinis pažymėjimas nustoja galioti, jei nustatoma, kad žala atsirado dėl netinkamo įrengimo. Pagrindas, ant kurio bus montuojamas produktas, turi būti lygus ir be didelių lygių skirtumų. Produktas turi būti pritvirtintas prie pagrindo. Pastaba: Visoms varžtams sutepti naudokite tepalą, kad išvengtumėte jų lūžimo. Įsitinkite, kad šiltnamio paletė negali apvirtti ir sukelti nelaimingų atsitikimų. Patikrinkite, ar paviršius, ant kurio pastatysite paletę, yra lygus. Dvių žemės kuoliukų įrengimas paletėje apsaugos ją nuo apvirtimo. Neišimkite visų medinių detalių iš paletės, tik tas, kurios būtinos norint pasiekti reikalingas dalis.

Montavimui reikalingi bent 2 žmonės.

SK

MONTÁŽNY NÁVOD

Dôležité: Pred začatím montáže si dôkladne prečítajte celý návod. Dôsledne dodržiavajte všetky pokyny uvedené v tejto príručke a vykonajte všetky kroky inštalácie v určenom poradí. Nedodržanie týchto pravidiel môže viesť k nesprávnej montáži dekoratívnych listů a vzniku vizuálnych chýb. Záruka je neplatná, ak sa zistí, že škoda bola spôsobená nesprávnou montážou. Základňa, na ktorú sa produkt inštaluje, musí byť rovná a bez výrazných výškových rozdielov. Produkt musí byť pripevnený k základni. Poznámka: Na všetky skrutky použite mazivo, aby sa predišlo ich zlomeniu. Uistite sa, že paleta skleníka sa nemôže prevrátiť a spôsobiť nehodu. Skontrolujte, či je povrch, na ktorý umiestnite paletu, rovný. Inštalácia dvoch zemných kotiev zabráni prevráteniu palety. Neodstraňujte všetky drevené prvky vo vnútri palety, iba tie, ktoré sú nevyhnutné na prístup k potrebným dielom.

Montáž vyžaduje minimálne 2 osoby.

SI

NAVODILA ZA SESTAVO

Pomembno: Pred začetkom sestavljanja natančno preberite celotna navodila. Strogo upoštevajte vsa navodila v tem priročniku in izvedite vse faze namestitve v določenem vrstnem redu. Neupoštevanje teh pravil lahko povzroči nepravilno pritrditev dekorativnih letvic in nastanek vizualnih napak. Garancija ni veljavna, če se ugotovi, da je bila škoda povzročena zaradi nepravilne namestitve. Osnova, na katero bo izdelek nameščen, mora biti ravna in brez večjih višinskih razlik. Izdelek mora biti pritrdjen na podlago. Opomba: Vse vijake premažite z mazivom, da preprečite njihovo zlom. Poskrbite, da se paleta rastlinjaka ne more prevrniti in povzročiti nesreč. Preverite, ali je površina, na katero postavite paletu, ravna. Namestitev dveh talnih sider bo preprečila prevrnitev. Ne odstranjujte vseh lesenih delov znotraj palete, temveč samo tiste, ki so potrebni za dostop do zelenih delov.

Za namestitev sta potrebni vsaj 2 osebi.

PL

INSTRUKCJA MONTAŻU

Ważne: Przed rozpoczęciem montażu należy dokładnie przeczytać całą instrukcję. Należy ściśle przestrzegać wszystkich wskazówek zawartych w niniejszym podręczniku i wykonywać wszystkie etapy instalacji w określonej kolejności. Nieprzestrzeganie tych zasad może skutkować nieprawidłowym zamontowaniem listew dekoracyjnych oraz wystąpieniem wad wizualnych. Certyfikat gwarancji traci ważność, jeśli zostanie stwierdzone, że uszkodzenia wynikły z nieprawidłowego montażu. Podstawa, na której montowany jest produkt, musi być płaska i pozbawiona znaczących różnic poziomu. Produkt musi być przymocowany do podstawy. Uwaga: Należy używać smaru do wszystkich śrub, aby zapobiec ich pękaniu. Upewnij się, że paleta szklarni nie może się przewrócić i spowodować wypadku. Sprawdź, czy podłoże, na którym ustawiasz paletę, jest wypoziomowane. Zamocowanie dwóch kotew gruntowych zapobiegnie jej przewróceniu. Nie usuwaj wszystkich drewnianych elementów wewnątrz palety, a jedynie te, które są konieczne do uzyskania dostępu do potrzebnych części. **Do montażu wymagane są co najmniej 2 osoby.**

HU

ÖSSZESZERELÉSI ÚTMUTATÓ

Fontos: Az összeszerelés megkezdése előtt olvassa el az egész útmutatót. Szigorúan kövesse a kézikönyvben megadott összes utasítást, és végezze el az összeszerelési lépéseket a megadott sorrendben. Az előírások be nem tartása a dekorációs lécek hibás felszereléséhez és esztétikai hibákhoz vezethet. A garancia érvénytelené válík, ha megállapítják, hogy a károk helytelen telepítésből adódtak. A termék alapjának síknak és jelentős szintkülönbségek nélkülinek kell lennie. A terméket rögzíteni kell az alaphoz. Megjegyzés: Minden csavart kenőanyaggal kell kezelni, hogy megelőzzük a törést. Biztosítsa, hogy az üvegház raklapja ne borulhasson fel és ne okozzon balesetet. Ellenőrizze, hogy a raklapot sík felületre helyezze-e. Két földhorgony felszerelése megakadályozza a felborulást. Ne távolítsa el az összes faelemet a raklapon belül, csak azokat, amelyek szükségesek a hozzáféréshez.

A telepítéshez legalább 2 személy szükséges.

HR

UPUTE ZA MONTAŻU

Važno: Prije početka montáže pažljivo pročitajte cijele upute. Strogo se pridržavajte svih smjernica u ovom priručniku i provodite sve faze instalacije prema navedenom redoslijedu. Nepoštivanje ovih pravila može dovesti do nepravilnog pričvršćivanja ukrasnih letvica i pojave vizualnih nedostataka. Jamstvo prestaje vrijediti ako se utvrdi da je šteta uzrokovana nepravilnom instalacijom. Podloga na koju se proizvod postavlja mora biti ravna i bez značajnih razlika u razini. Proizvod mora biti pričvršćen za podlogu. Napomena: Koristite mazivo na svim vijcima kako biste spriječili njihovo pucanje. Osigurajte da paleta staklenika ne može pasti i uzrokovati nesreću. Provjerite je li podloga na kojoj postavljate paletu ravna. Postavljanje dviju zemaljskih sidara na paletu spriječit će njezino prevrtanje. Nemojte uklanjati sve drvene dijelove unutar palete, već samo one koji su nužni za pristup potrebnim dijelovima.

Za montážu su potrebne najmanje 2 osobe.

CZ

MONTÁŽNÍ NÁVOD

Důležité: Před zahájením montáže si pečlivě přečtěte celý návod. Písrně dodržujte všechny pokyny uvedené v této příručce a postupujte podle instalačních kroků ve stanoveném pořadí. Nedodržení těchto pravidel může vést k nesprávné instalaci dekorativních listů a vzniku vizuálních vad. Záruka se stává neplatnou, pokud se zjistí, že škoda byla způsobena nesprávnou instalací. Základna, na kterou bude produkt instalován, musí být rovná a bez výrazných výškových rozdílů. Produkt musí být připevněn k základně. Poznámka: Použijte mazivo na všechny šrouby, aby nedošlo k jejich zlomení. Ujistěte se, že paleta skleníku nemůže převrhnout a způsobit nehodu. Zkontrolujte, zda je povrch, na který umístíte paletu, vyrovnaný. Instalace dvou zemních hřebů do palety zabráni jejímu převrácení. Neodstraňujte všechny dřevěné prvky uvnitř palety, pouze ty, které jsou nutné k přístupu k potřebným částem.

Montáž vyžaduje alespoň 2 osoby.

RO

INSTRUCȚIUNI DE ASAMBLARE

Important: Citiți cu atenție întreaga instrucțiune înainte de a începe asamblarea. Respectați cu strictețe toate indicațiile din acest manual și efectuați toate etapele instalării în ordinea specificată. Nerespectarea acestor reguli poate duce la o montare incorectă a ornamentelor decorative și la apariția unor defecte vizuale. Certificatul de garanție devine nul dacă se constată că daunele au fost cauzate de o instalare incorectă. Baza pe care se montează produsul trebuie să fie plană și fără diferențe semnificative de nivel. Produsul trebuie fixat pe bază. Notă: Folosiți lubrifiant pentru toate șuruburile pentru a preveni ruperea acestora. Asigurați-vă că paletul seriei nu se poate răsturna și provoca accidente. Verificați ca suprafața pe care puneți paletul să fie nivelată. Instalarea a două ancore de sol pe palet va preveni răsturnarea acestuia. Nu îndepărtați toate elementele de lemn din palet, doar cele necesare pentru a accesa piesele de care aveți nevoie.

Instalarea necesită cel puțin 2 persoane.

BG

ИНСТРУКЦИИ ЗА СГЛОБЯВАНЕ

Важно: Прочетете внимателно цялата инструкция преди да започнете сглобяването. Стриктно спазвайте всички указания в това ръководство и изпълнявайте всички етапи на монтажа в зададената последователност. Неспазването на тези правила може да доведе до неправилен монтаж на декоративните елементи и визуални дефекти. Гаранционният сертификат става невалиден, ако се установи, че повредите са причинени от неправилна инсталация. Основата, върху която ще се монтира продуктът, трябва да бъде равна и без значителни разлики в нивото. Продуктът трябва да бъде закрепен към основата. Забележка: Използвайте лубрикант за всички винтове, за да предотвратите тяхното счупване. Уверете се, че палетата на оранжерията не може да се преобърне и да причини инциденти. Проверете дали повърхността, върху която поставяте палетата, е нивелирана. Монтирането на два земни анкера в палетата ще предотврати нейното преобръщане. Не премахвайте всички дървени елементи вътре в палетата, а само тези, които са необходими за достъп до желаните части. **За монтажа са необходими поне 2 души.**

GR

ΟΔΗΓΙΕΣ ΣΥΝΑΡΜΟΛΟΓΗΣΗΣ

Σημαντικό: Διαβάστε προσεκτικά όλες τις οδηγίες πριν ξεκινήσετε τη συναρμολόγηση. Ακολουθήστε αυστηρά όλες τις οδηγίες αυτού του εγχειριδίου και εκτελέστε όλα τα στάδια της εγκατάστασης με την καθορισμένη σειρά. Η μη τήρηση αυτών των κανόνων μπορεί να οδηγήσει σε λανθασμένη τοποθέτηση των διακοσμητικών λωρίδων και την εμφάνιση οπτικών ελαττωμάτων. Η εγγύηση παύει να ισχύει εάν διαπιστωθεί ότι η ζημιά προκλήθηκε από εσφαλμένη εγκατάσταση. Η βάση στην οποία θα τοποθετηθεί το προϊόν πρέπει να είναι επίπεδη και χωρίς σημαντικές διαφορές ύψους. Το προϊόν πρέπει να στερεωθεί στη βάση. Σημείωση: Χρησιμοποιήστε λιπαντικό σε όλες τις βίδες για να αποφύγετε το σπάσιμο. Βεβαιωθείτε ότι η παλέτα του θερμοκηπίου δεν μπορεί να ανατραπεί και να προκαλέσει ατυχήματα. Ελέγξτε ότι το έδαφος όπου τοποθετείτε την παλέτα είναι επίπεδο. Η τοποθέτηση δύο αγκυρών εδάφους στην παλέτα θα αποτρέψει την ανατροπή της. Μην αφαιρείτε όλα τα ξύλινα στοιχεία στο εσωτερικό της παλέτας, μόνο αυτά που είναι απαραίτητα για την πρόσβαση στα απαιτούμενα εξαρτήματα. **Για την εγκατάσταση απαιτούνται τουλάχιστον 2 άτομα.**

IT

ISTRUZIONI DI MONTAGGIO

Importante: Leggere attentamente l'intero manuale prima di iniziare il montaggio. Seguire rigorosamente tutte le istruzioni fornite in questo manuale e completare tutte le fasi del processo di installazione nell'ordine specificato. Il mancato rispetto di queste regole potrebbe portare a un fissaggio errato delle modanature decorative e a difetti visivi. Il certificato di garanzia diventa nullo se i danni sono causati da un'installazione errata. La base su cui verrà installato il prodotto deve essere piana e priva di differenze di livello significative. Il prodotto deve essere fissato alla base. Nota: Applicare lubrificante su tutte le viti per evitare rotture. Assicurarsi che il pallet della serra non possa ribaltarsi e causare incidenti. Controllare che il terreno su cui si posiziona il pallet sia livellato. L'installazione di due ancoraggi a terra eviterà il ribaltamento. Non rimuovere tutte le strutture in legno all'interno del pallet, solo quelle necessarie per accedere alle parti richieste.

L'installazione richiede almeno 2 persone.

MT

ISTRUZZJONIJIET GĦALL-ASSEMBLAĠĠ

Importanti: Aqra l-istruzzjonijiet kollha qabel tibda l-assemblaġġ. Segwi b'attenzjoni l-passi kollha f'dan il-manwal u wettaq il-proċedura ta' installazzjoni fl-ordni speċifikata. Nuqqas ta' konformità ma' dawn ir-regoli jista' jwassal għal assemblaġġ ħażin tal-linji dekorattivi u difetti viżwali. Iċ-certifikat tal-garanzija jsir invalidu jekk jinstab li l-ħsarat ġew ikkawżati minn installazzjoni mhux korretta. Il-bażi fuq liema se tiġi installata l-prodott trid tkun ċatta u mingħajr differenzi sinifikanti fil-livell. Il-prodott għandu jkun imsakkar mal-bażi. Nota: Uża lubrikant fuq il-viti kollha biex tevita li jinkisru. Kun żgur li l-pallet tas-serra ma jstax jaqqa' u jikkawża incidenti. Iċ-ċekkja li l-art fejn se tqiegħed il-pallet hija livellata. L-installazzjoni ta' żewġ ankri tal-art fil-pallet tipprevjeni li din tinqaleb. Tneħħix l-elementi kollha tal-injam ġewwa l-pallet, ħlief dawk meħtieġa biex ikollok aċċess għall-partijiet meħtieġa.

L-assemblaġġ jeħtieġ mill-inqas 2 persuni.

IE

TREORACHA TIONÓLA

Tábhachtach: Léigh an treoir iomlán sula dtosaíonn tú ar an tionól. Lean go docht gach treoir atá sa lámhleabhar seo agus cuir gach céim den phróiseas suiteála i gcrích san ord sonraithe. Má theipeann ort na rialacha seo a chomhlíonadh, d'fhéadfadh tionól mícheart na hailt mhaisiúcháin agus lochtanna amhairc tarlú. Beidh an teastas bharánta neamhbhailí má chuirtear damáiste i leith suiteáil mhícheart. Caithfidh an dromchla ar a gcuirfear an táirge a bheith cothrom agus gan aon difríochtaí suntasacha airde. Caithfear an táirge a dhaingniú leis an mbonn. Nóta: Bain úsáid as bealadh ar na scriúna go léir chun iad a chosaint ar bhriseadh. Cinntigh nach féidir le pailléid an cheaptha teasa titim agus timpistí a chruthú. Cinntigh go bhfuil an talamh ina gcuirtear an phailléid cothrom. Cuir dhá thaca talún leis an bpailléid chun í a chosc ó thitim. Ná bain na struchtúir adhmaid uile istigh sa phailléid, ach amháin na cinn is gá chun rochtain a fháil ar na codanna a theastaíonn uait.

Teastaíonn ar a laghad 2 dhuine don suiteáil.

ES

INSTRUCCIONES DE MONTAJE

Importante: Lea completamente las instrucciones antes de comenzar el montaje. Siga estrictamente todas las indicaciones de este manual y realice todas las etapas del proceso de instalación en el orden especificado. El incumplimiento de estas normas puede provocar una colocación incorrecta de las molduras decorativas y la aparición de defectos visuales. El certificado de garantía quedará anulado si se determina que los daños fueron causados por una instalación incorrecta. La base sobre la que se instalará el producto debe ser plana y sin diferencias significativas de nivel. El producto debe estar fijado a la base. Nota: Utilice lubricante en todos los tornillos para evitar que se rompan. Asegúrese de que el palé del invernadero no pueda volcarse y causar accidentes. Verifique que la superficie donde coloque el palé esté nivelada. La instalación de dos anclajes al suelo en el palé evitará su vuelco. No retire todas las estructuras de madera dentro del palé, solo las necesarias para acceder a las piezas requeridas. **Para la instalación se requieren al menos 2 personas.**

NL

MONTAGE-INSTRUCTIES

Belangrijk: Lees de volledige instructies voordat u met de montage begint. Volg strikt alle instructies in deze handleiding en voer alle installatiestappen in de aangegeven volgorde uit. Niet-naleving van deze regels kan leiden tot een onjuiste bevestiging van de decoratieve latten en visuele gebreken. De garantie vervalt als blijkt dat schade is veroorzaakt door een onjuiste installatie. De ondergrond waarop het product wordt geïnstalleerd, moet vlak zijn en mag geen significante hoogteverschillen vertonen. Het product moet aan de basis worden bevestigd. Opmerking: Gebruik smeermiddel op alle schroeven om breuk te voorkomen. Zorg ervoor dat de pallet van de kas niet kan omvallen en ongelukken kan veroorzaken. Controleer of de grond waarop u de pallet plaatst, vlak is. Het installeren van twee grondankers in de pallet voorkomt kantelen. Verwijder niet alle houten steunen binnenin de pallet, alleen die nodig zijn om toegang te krijgen tot de vereiste onderdelen.

Voor de installatie zijn minimaal 2 personen nodig.

PT

INSTRUÇÕES DE MONTAGEM

Importante: Leia atentamente todas as instruções antes de iniciar a montagem. Siga rigorosamente todas as diretrizes deste manual e realize todas as etapas do processo de instalação na ordem especificada. O não cumprimento destas regras pode resultar numa fixação incorreta das ripas decorativas e em defeitos visuais. O certificado de garantia será anulado se for constatado que os danos foram causados por uma instalação incorreta. A base onde o produto será instalado deve ser plana e sem diferenças de nível significativas. O produto deve ser fixado à base. Nota: Utilize lubrificante em todos os parafusos para evitar que se partam. Certifique-se de que o palete da estufa não possa tombar e causar acidentes. Verifique se o solo onde será colocado o palete está nivelado. A instalação de duas estacas no solo evitará que o palete tombe. Não remova todas as peças de madeira dentro do palete, apenas as necessárias para acessar as peças desejadas.

A instalação requer pelo menos 2 pessoas.

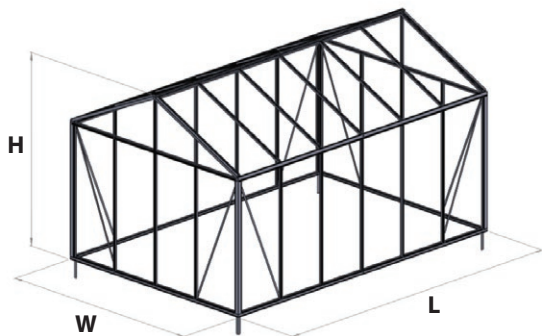

CLASSIC PREMIUM

W (mm)	L (mm)	H (mm)	(mm)	(mm)	m ²	
2352	1606	2333	1769	1669	3,77	1
2352	2352	2333	1769	1669	5,53	1
2352	3098	2333	1769	1669	7,29	1
2352	3844	2333	1769	1669	9,04	2
2352	4590	2333	1769	1669	10,80	3
2352	5336	2333	1769	1669	12,55	4
2352	6082	2333	1769	1669	14,30	4
3098	1606	2678	1940	1840	4,97	1
3098	2352	2678	1940	1840	7,29	1
3098	3098	2678	1940	1840	9,60	1
3098	3844	2678	1940	1840	11,91	2
3098	4590	2678	1940	1840	14,22	3
3098	5336	2678	1940	1840	16,53	4
3098	6082	2678	1940	1840	18,84	4

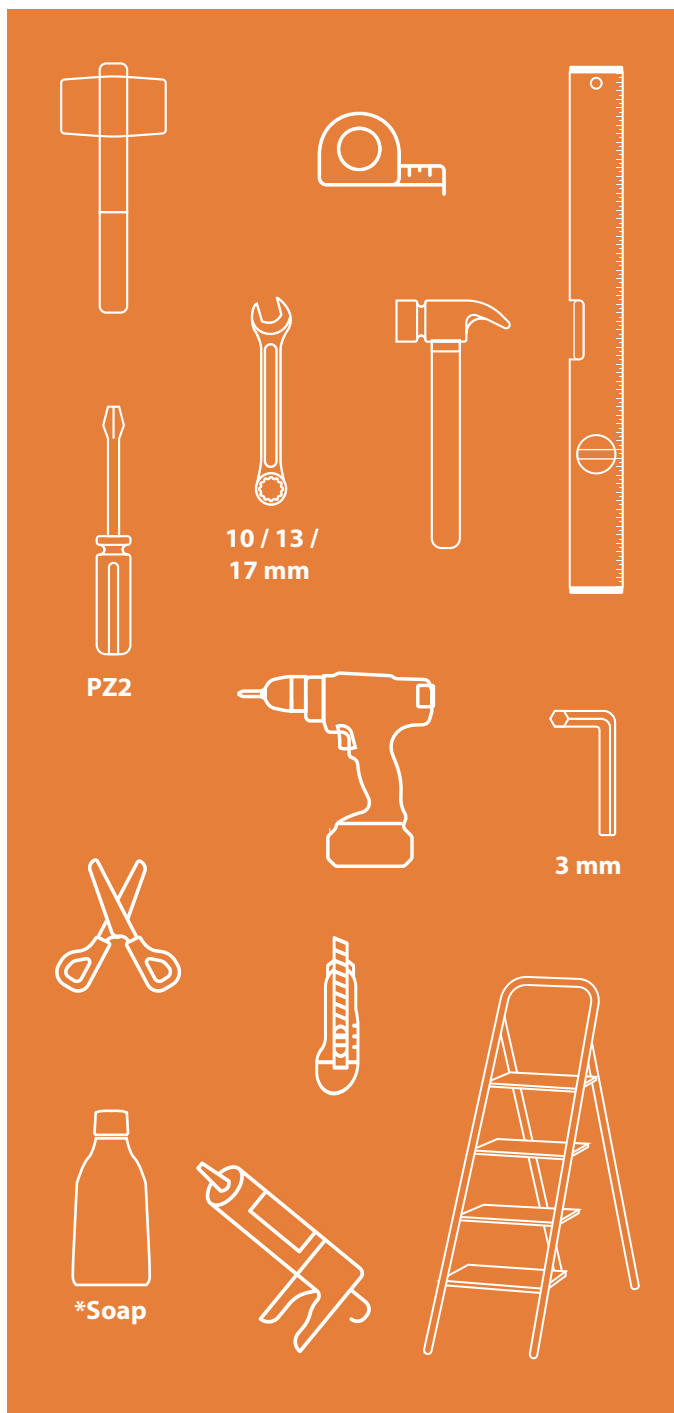

UK: Necessary tools – rubber mallet, measuring tape, spirit level, screwdriver PZ2, wrenches 10/13/17 mm, cordless drill, 3 mm hex key, utility knife, *soap for rubber when oil is not enough, silicone gun and silicone, ladder.

SE: Nödvändiga verktyg - Gummihammare, måttband, vattenpass, skruvmejsel PZ2, skiftnycklar 10/13/17 mm, batteridrivnen skruvdragare, 3 mm insexnyckel, brytbladskniv, *tvål för gummit när oljan inte räcker till, silikonpistol och silikon, stega.

NO: Nødvendige verktøy - Gummihammer, målebånd, vater, skrutrekker PZ2, skrunøkler 10/13/17 mm, batteridrevet skrutrekker, 3 mm unbrakonøkkel, tapetkniv, *såpe for gummen når oljen ikke er nok, silikonpistol og silikon, stige.

DK: Nødvendigt værktøj - Gummihammer, målebånd, vaterpas, skruetrækker PZ2, skruenøgler 10/13/17 mm, batteridrevet skruetrækker, 3 mm unbrakonøgle, hobbykniv, *såbe til gummet, når olien ikke er nok, silikonpistol og silikon, stige.

FI: Tarvittavat työkalut - Kumivasara, mittanauha, vatupassi, ruuvimeisseli PZ2, avaimet 10/13/17 mm, akkuruuviväänin, 3 mm kuusiokoloavain, mattoveitsi, saippua kumille, *kun öljy ei riitä, silikonipistooli ja silikon, tikkaat.

DE: Notwendige Werkzeuge - Gummihammer, Maßband, Wasserwaage, Schraubendreher PZ2, Schraubenschlüssel 10/13/17 mm, Akku-Schraubendreher, 3 mm Innensechskantschlüssel, Cutter-Messer, *Seife für das Gummi wenn das Öl nicht ausreicht, Silikonpistole und Silikon, Leiter.

FR: Outils nécessaires - Maillet en caoutchouc, mètre ruban, niveau à bulle, tournevis PZ2, clés 10/13/17 mm, tournevis sans fil, clé hexagonale de 3 mm, cutter, *savon pour le caoutchouc lorsque l'huile ne suffit pas, pistolet à silicone et silicone, échelle.

LV: Nepieciešamie instrumenti - Gumijas āmurs, mērlente, līmenrādis, skrūvgrieznis PZ2, uzgriezņu atslēgas 10/13/17 mm, akumulatora skrūvgrieznis, 3 mm seškante, papīrnāzis, *ziepes gumijām (kad nepietiek ar eļļu), silikona pistole un silikons, trepes.

EE: Vajalikud tööriistad - Kummivasara, mõõdulint, lood, kruvikeeraja PZ2, mutrivõtmed 10/13/17 mm, akukruvikeeraja, 3 mm kuuskantvõti, paberinuga, *seep ummi jaoks (kui õli ei ole piisavalt), silikonipistool ja silikon, redel.

LT: Reikalingi įrankiai - Guminis plaktukas, matavimo juosta, gulsčiukas, atsuktuvus PZ2, veržliaraktiai 10/13/17 mm, akumuliatorinis atsuktuvus, 3 mm šešiakampis raktas, popierinis peilis, *muilas gumei (kai aliejaus nepakanka), silikono pistoletas ir silikonas, kopėčios.

PL: Niezbędne narzędzia - Młotek gumowy, miarka, poziomica, śrubokręt PZ2, klucze 10/13/17 mm, wkrętarka akumulatorowa, klucz imbusowy 3 mm, nóż do tapet, *mydło do gumy (gdą oleju jest za mało), pistolet do silikonu i silikon, drabina.

CZ: Potřebné nástroje - Gumová palice, svinovací metr, vodováha, šroubovák PZ2, klíče 10/13/17 mm, akumulátorový šroubovák, 3mm imbusový klíč, řezací nůž, *mýdlo pro gumu (když olej nestačí), silikonová pistole a silikon, žebřík.

SK: Potřebné nástroje - Gumové kladivo, meter, vodováha, skrutkovač PZ2, klúče 10/13/17 mm, akumulátorový skrutkovač, 3 mm imbusový klúč, rezač, *mydlo pre gumu (keď olej nestačí), silikónová pištoľ a silikón, rebrík.

HU: Szükséges szerszámok - Gumikalapács, mérőszalag, vízmérték, PZ2 csavarhúzó, villáskulcsok 10/13/17 mm, akkumulátoros csavarhúzó, 3 mm imbuskulcs, sniccer, *szappan a gumihoz (ha az olaj nem elég), szilikonpisztoly és szilikon, létra.

RO: Unele necesare - Ciocan din cauciuc, ruletă, nivelă, șurubelniță PZ2, chei 10/13/17 mm, șurubelniță cu acumulator, cheie imbus de 3 mm, cutter, *șăpun pentru cauciuc (când uleiul nu este suficient), pistol de silicon și silicon, scară.

SI: Potrebna orodja - Gumijasto kladivo, merilni trak, vodna tehtnica, izvijač PZ2, ključiči 10/13/17 mm, akumulatorski izvijač, 3 mm imbus ključ, olfa nož, *milo za gumo (kadar olje ni dovolj), pištola za silikon in silikon, lestev.

HR: Potrebni alati - Gumeni čekić, metar, libela, odvijač PZ2, ključevići 10/13/17 mm, akumulatorski odvijač, 3 mm imbus ključ, skalpel, *sapun za gumu kada ulje nije dovoljno, pištolj za silikon i silikon, ljestve.

BG: Необходими инструменти - Гумен чук, рулетка, нивелир, отвертка PZ2, гаечни ключове 10/13/17 mm, акумулаторна отвертка, 3 mm шестограм, макетен нож, *сапун за гумата когато маслото не е достатъчно, пистолет за силикон и силикон, стълба.

GR: Απαραίτητα εργαλεία - Σφυρί από καουτσούκ, μεζούρα, αλφάδι, καταβίδι PZ2, κλειδιά 10/13/17 mm, καταβίδι μπαταρίας, κλειδί άλεν 3 mm, κοπίδι, *σαπούνι για το καουτσούκ όταν το λάδι δεν είναι αρκετό, πιστόλι σιλικόνης και σιλικόνη, σκάλα.

IE: Uirlisi riachtanacha - Casúr rubair, téip tomhais, leibhéal, scriúire PZ2, eochracha 10/13/17 mm, scriúire ceallraí, heisceagán 3 mm, scian páipéir, *gallúnach don rubar nuair nach bhfuil an ola go leor, piostal shilicóne agus silicóne, dréimire.

NL: Benodigde gereedschappen - Rubberen hamer, meetlint, waterpas, schroevendraaier PZ2, steeksleutels 10/13/17 mm, accu-schroevendraaier, 3 mm inbussleutel, stanley mes, *zeep voor het rubber als de olie niet genoeg is, kitpistool en siliconen, ladder.

IT: Strumenti necessari - Martello in gomma, metro a nastro, livella, cacciavite PZ2, chiavi 10/13/17 mm, cacciavite a batteria, chiave a brugola da 3 mm, tagliarino, *sapone per la gomma quando l'olio non è sufficiente, pistola per silicone e silicone, scala.

ES: Herramientas necesarias - Martillo de goma, cinta métrica, nivel, destornillador PZ2, llaves 10/13/17 mm, destornillador inalámbrico, llave Allen de 3 mm, cúter, *jabón para el caucho cuando el aceite no es suficiente, pistola de silicona y silicona, escalera.

PT: Ferramentas necessárias - Martelo de borracha, fita métrica, nível, chave de fendas PZ2, chaves 10/13/17 mm, chave de fendas elétrica, chave Allen de 3 mm, faca de papel, *sabão para a borracha quando o óleo não for suficiente, pistola de silicone e silicone, escada.

MT: Ghodda meħtieġa - Mazzun tal-lastiku, tejp tal-kejl, livell, tornavit PZ2, ċwieviet 10/13/17 mm, tornavit bil-batterija, ċavetta Allen ta' 3 mm, sikkina tal-karta, *sapun għall-gomma meta ż-żajt ma jkun biżżejjed, pistola tas-silikon u silikon, sellu.

FOUNDATION PLAN

4 corners are concreted, the base profile placed on a solid foundation

SE: Grundplan

4 hörn är gjutna i betong, basprofilen placeras på en solid grund

NO: Fundamentplan

4 hjørner er støbt i betong, baseprofilen plasseres på et solid fundament

DK: Fundamentplan

4 hjørner er støbt i betong, baseprofilen placeres på et solidt fundament

FI: Perustussuunnitelma

4 kulmaa on valettu betoniin, perusprofiili asetetaan vakaalle perustalle

DE: Fundamentplan

4 Ecken sind einbetoniert, das Basisprofil wird auf einem soliden Fundament platziert

FR: Plan de fondation

4 coins sont bétonnés, le profil de base est placé sur une fondation solide

LV: Pamatu plāns

4 stūri ir ielieti betonā, pamatprofils novietots uz stabila pamata

EE: Vundamendiplaan

4 nurka on betoneeritud, alusprofiil asetatakse tugevale vundamendile

LT: Pamatų planas

4 kampai yra užbetonuoti, pagrindo profilis padėtas ant tvirto pamato

PL: Plan fundamentu

4 narożniki są zabetonowane, profil bazowy umieszczony na solidnym fundamencie

CZ: Plán základů

4 rohy jsou zabetonovány, základní profil umístěn na pevném základu

SK: Plán základu

4 rohy sú zabetónované, základný profil umiestnený na pevnom základe

HU: Alapozási terv

4 sarok be van betonozva, az alapprofil szilárd alpra van helyezve

RO: Plan fundație

4 colțuri sunt turnate în beton, profilul de bază este plasat pe o fundație solidă

SI: Načrt temelja

4 vogali so betonirani, osnovni profil je postavljen na trdno temelje

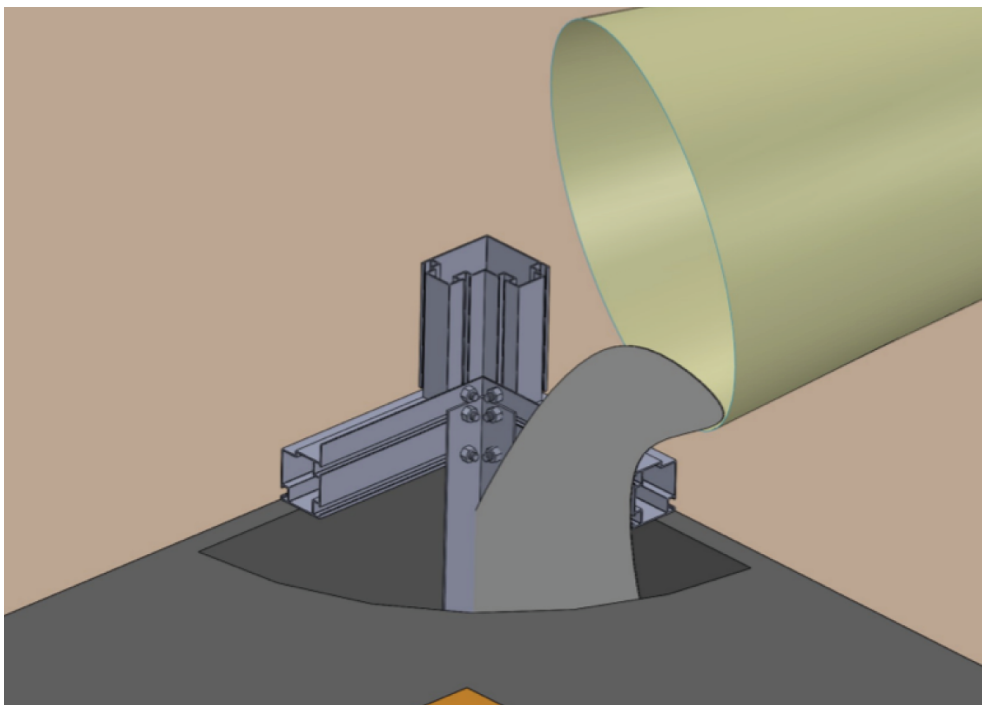
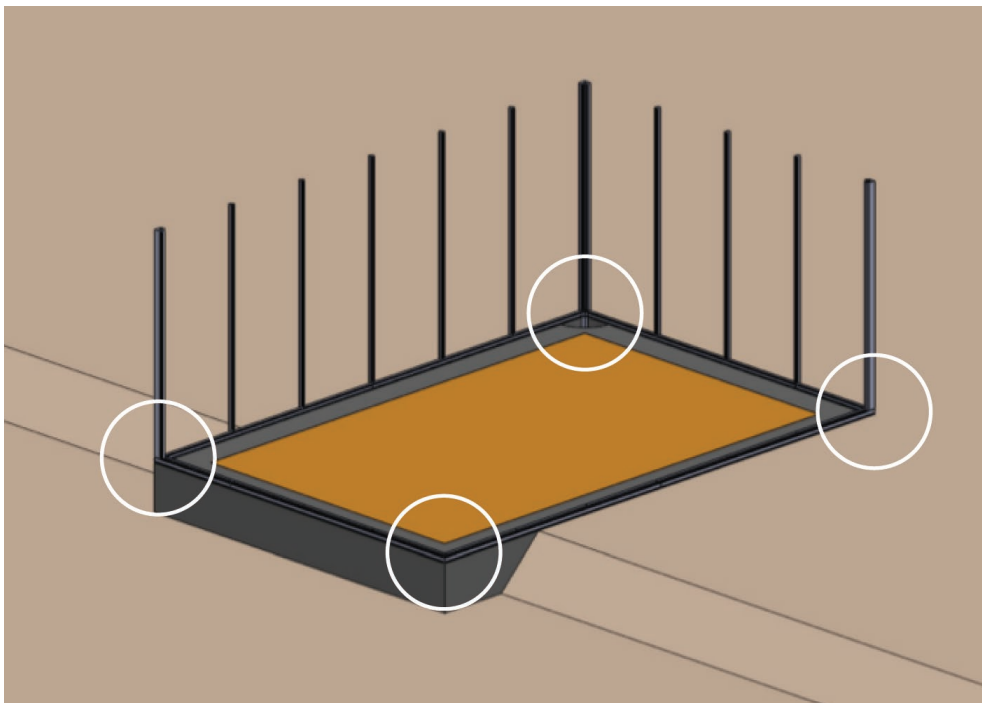

HR: Plan temelja

4 kuta su betonirana, osnovni profil postavljen je na čvrste temelje

BG: План на основата

4 ъгъла са бетонирани, основният профил е поставен върху здрава основа

GR: Σχέδιο θεμελίωσης

4 γωνίες είναι τσιμεντωμένες, το βασικό προφίλ τοποθετείται σε σταθερό θεμέλιο

IE: Plean Fondúireachta

Tá 4 choirméal coincreítithe, tá an phróifíl bhunúsach curtha ar bhunchloch dhaignean

NL: Funderingsplan

4 hoeken zijn in beton gegoten, het basisprofiel geplaatst op een solide fundering

IT: Piano di fondazione

4 angoli sono cementati, il profilo di base è posizionato su una solida fondazione

ES: Plan de cimentación

4 esquinas están cementadas, el perfil base colocado sobre una cimentación sólida

PT: Plano de fundação

4 cantos são cimentados, o perfil base colocado sobre uma fundação sólida

MT: Pjan tal-fondazzjoni

4 kantunieri huma kkokmati fil-konkos, il-profil bażi jitqiegħed fuq fondazzjoni solida

IF CORNER REINFORCEMENTS ARE NOT USED

SE: Om hörnförstärkningar inte används:

1. Borra hål i profilen.
2. Fäst basen med plugg och skruv.
3. Använd plastskydd för hål

NO: Hvis hjørneforsterkninger ikke brukes:

1. Bor hull i profilen
2. Fest basen med plugg og skruve
3. Bruk plastdeksler for hull

DK: Hvis hjørneforstærkninger ikke bruges:

1. Bor huller i profilen
2. Fastgør basen med plug og skruve
3. Brug plastdæksler til huller

FI: Jos kulmavahvikeita ei käytetä:

1. Poraa reiät profiiliin
2. Kiinnitä pohja tulpalla ja ruuvilla
3. Käytä muovisuojia reikiin

DE: Wenn Keine Eckverstärkungen Verwendet

Werden:

1. Löcher in das Profil bohren
2. Basis mit Dübel und Schraube befestigen
3. Verwenden Sie Kunststoffabdeckungen für Löcher

FR: Si les renforts d'angle ne sont pas utilisés:

1. Percez des trous dans le profilé
2. Fixez la base avec une cheville et une vis
3. Utilisez des caches en plastique pour les trous

LV: Ja netiek izmantoti stūra stiprinājumi:

1. Izurbiet caurumus profilā
2. Piestipriniet pamatni ar dibeli un skrūvi
3. Izmantojiet plastmasas pārsegus caurumiem

EE: Kui nurgatugevdust ei kasutata:

1. Puurige profiili augud
2. Kinnitage alus tüübli ja kruviga
3. Kasutage aukude jaoks plastkatteid

LT: Jei kampo stiprinimai nenaudojami:

1. Išgręžkite skylės profilyje
2. Tvirtinkite pagrindą kaiščiu ir varžtu
3. Naudokite plastikinius dangtelius skylėms

PL: Jeśli wzmocnienia narożników nie

Są używane:

1. Wywierć otwory w profilu
2. Zamocuj podstawę kołkiem i śrubą
3. Użyj plastikowych zaślepek do otworów

CZ: Pokud nejsou použity rohové výztuhy:

1. Vyrvejte otvory v profilu
2. Připevněte základnu pomocí hmoždinky a šroubu
3. Použijte plastové krytky na otvory

SK: Ak nie sú použité rohové výztuhy:

1. Vŕtajte otvory v profile
2. Prichyťte základňu pomocou hmoždinky a skrutky
3. Použite plastové krytky na otvory

HU: Ha sarkantyú erősítések nem használnak:

1. Fúrjon lyukakat a profilba
2. Rögzítse az alapot dübellel és csavarral
3. Használjon műanyag fedőket a lyukakra

RO: Dacă nu se folosesc întăririi de colț:

1. Găuriți găuri în profil
2. Asigurați baza cu diblu și șurub
3. Folosiți capace din plastic pentru găuri

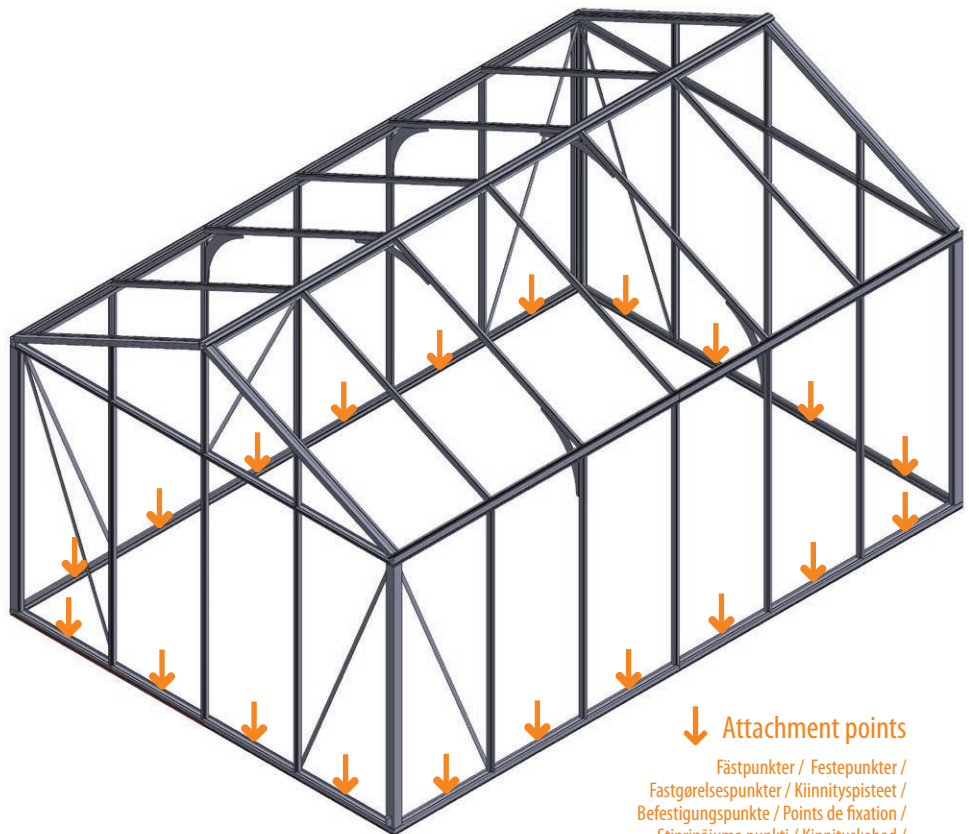

↓ Attachment points

Fästpunkter / Feste punkter / Fastgørelsespunkter / Kiinnityspisteet / Befestigungspunkte / Points de fixation / Stiprinājuma punkti / Kinnituskohad / Tvirtinimo taškai / Punkty mocowania / Montážní body / Miesta pripavenia / Rögzítési pontok / Puncte de fixare / Priključne točke / Točke pričvrščivanja / Точки за закрепване / Σημεία στερέωσης / Põnta ceangail / Bevestigingspunten / Punti di fissaggio / Puntos de fijación / Pontos de fixação / Punti ta' fissaġġ

1. Drill holes in profile
2. Secure base with dowel and screw
3. Use plastic covers for holes



SI: Če ne uporabljate kotne ojačitve:

1. Izvrtajte luknje v profilu
2. Pripnite osnovno z vložkom in vijakom
3. Uporabite plastične pokrovice za luknje

HR: Ako se ne koriste ojačanja u kutu:

1. Izbušite rupe u profilu
2. Pričvrstite bazu čepom i vijkom
3. Използвайте пластмасови капачки за дупки

BG: Ако не се използват ъглови усилвания:

1. Пробийте отвори в профила
2. Закрепете основата с дюбел и винт
3. Използвайте пластмасови капачки за дупки

GR: Αν δεν χρησιμοποιούνται ενισχυσεις γωνιας:

1. Τρυπήστε οπές στο προφίλ
2. Στερεώστε τη βάση με βύσμα και βίδα
3. Χρησιμοποιήστε πλαστικά καλύμματα για τρύπες

IE: Má níl úsáid agus foráís coirn:

1. Druileáil poill sa phróifíl
2. Daingnigh an bun le dubh agus scríú
3. Úsáid clúdaigh phlaisteacha do phoill

NL: Als hoekversterkingen niet worden Gebruikt:

1. Boor gaten in het profiel
2. Bevestig de basis met plug en schroef
3. Gebruik plastic afdekkappen voor gaten

IT: Se non si utilizzano rinforzi angolari:

1. Praticare fori nel profilo
2. Fissare la base con tassello e vite
3. Utilizzare coperture in plastica per i fori

ES: Si no se utilizan refuerzos de esquina:

1. Taladre agujeros en el perfil
2. Asegure la base con taco y tornillo
3. Utilice cubiertas de plástico para los agujeros

PT: Se não forem utilizados reforços de canto:

1. Fure furos no perfil
2. Fixe a base com bucha e parafuso
3. Use tampas de plástico para os buracos

MT: Jekk ma jużawx saffi ta' rinforz fil-kantunieri:

1. Ibbqum toħroġ toqob fil-profil
2. Iġġib il-bażi f' postha bil-ponta u s-sriep
3. Uża għotjien tal-plastik għall-toqob

EXTENSIONS

Fix extension rod in place with screw

SE: Förlängningar

Fäst förlängningsstången på plats med en skruv

NO: Forlengelser

Fest forlengelsesstangen på plass med en skrue

DK: Forlængelser

Fastgør forlængerstangen på plads med en skrue

FI: Jatkokappaleet

Kiinnitä jatkotanko paikalleen ruuvilla

DE: Verlängerungen

Befestige die Verlängerungsstange mit einer Schraube

FR: Rallonges

Fixez la tige d'extension en place avec une vis

LV: Pagarinājumi

Nostipriniet pagarinājuma stieni vietā ar skrūvi

EE: Pikendused

Kinnitage pikendustoru kruviga oma kohale

LT: Pratęsimai

Priveržkite prailginimo strypą varžtu

PL: Przedłużenia

Zamocuj pręt przedłużający na miejscu za pomocą śruby

CZ: Prodloužení

Pripevňte prodloužovací tyč na místo šroubem

SK: Predĺženia

Prichyťte predĺžovacia tyč na miesto skrutkou

HU: Hosszabbítások

Rögzítse a hosszabbító rudat csavarral

RO: Extensii

Fixați tija de extensie în poziție cu un șurub

SI: Podaljški

Pripnite podaljšano palico na mesto z vijakom

HR: Produžeci

Pričvrstite produžnu šipku na mjesto pomoću vijka

BG: Удължения

Закрепете удължителния прът с винт

GR: Επέκτασις

Στερεώστε τη ράβδο επέκτασης στη θέση της με μια βίδα

IE: Síneadh

Ceangail an tslat síneadh ina háit le scriú

NL: Verlengingen

Bevestig de verlengstang op zijn plaats met een schroef

IT: Estensioni

Fissa l'asta di estensione in posizione con una vite

ES: Extensiones

Fija la barra de extensión en su lugar con un tornillo

PT: Extensões

Fixe a haste de extensão no lugar com um parafuso

MT: Estensjoni

Issettja l-virga ta' estensjoni f'posha b'viti

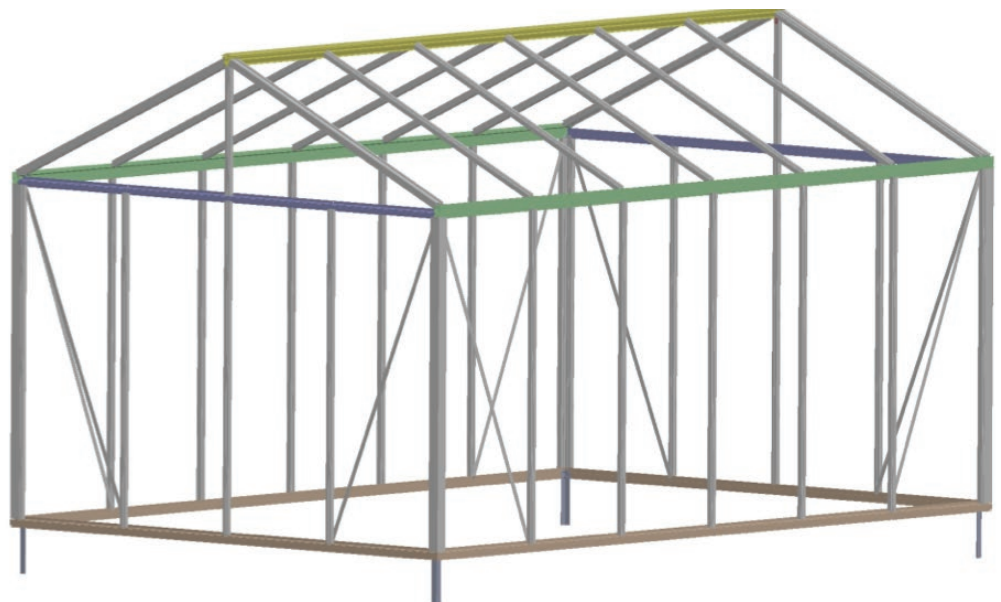
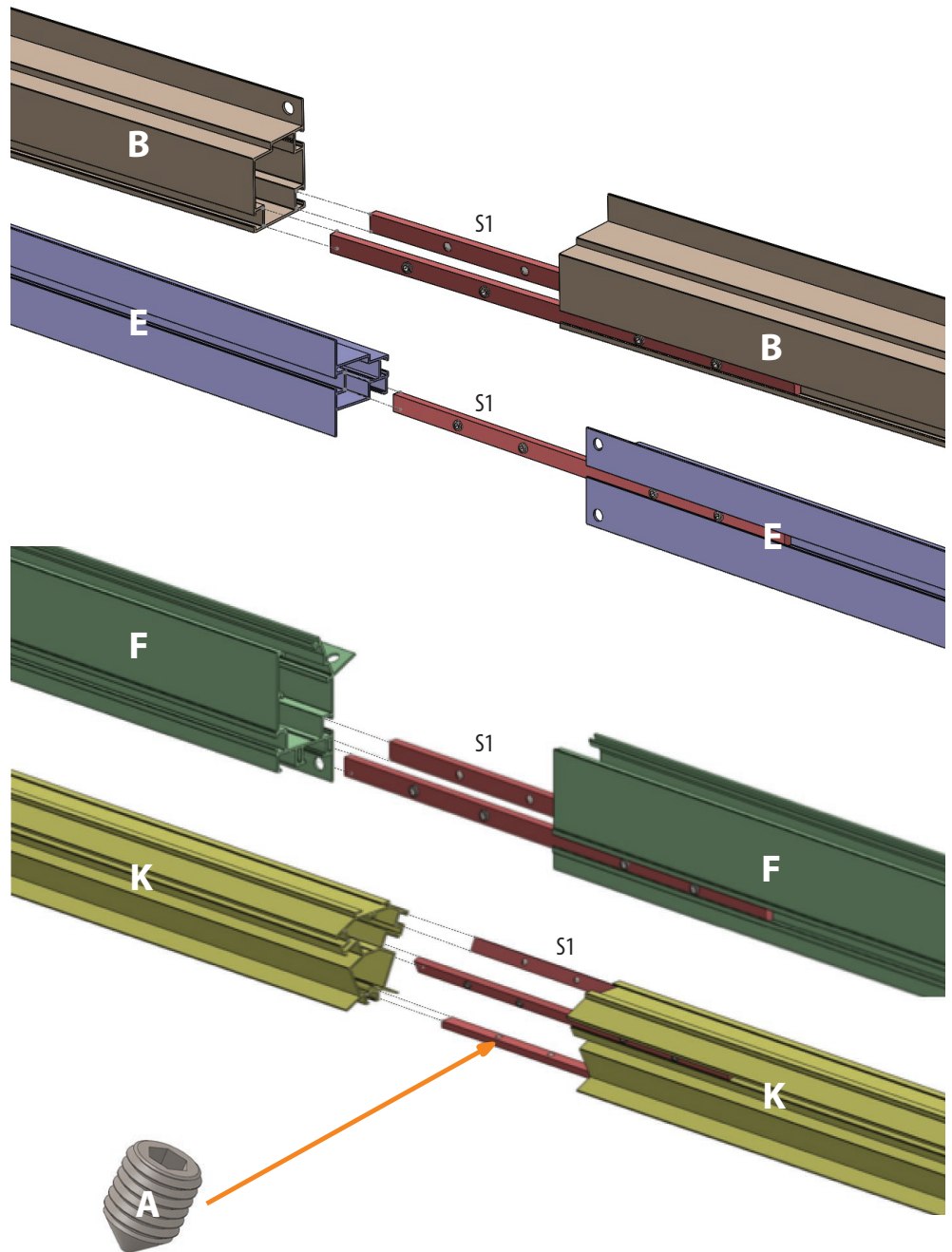

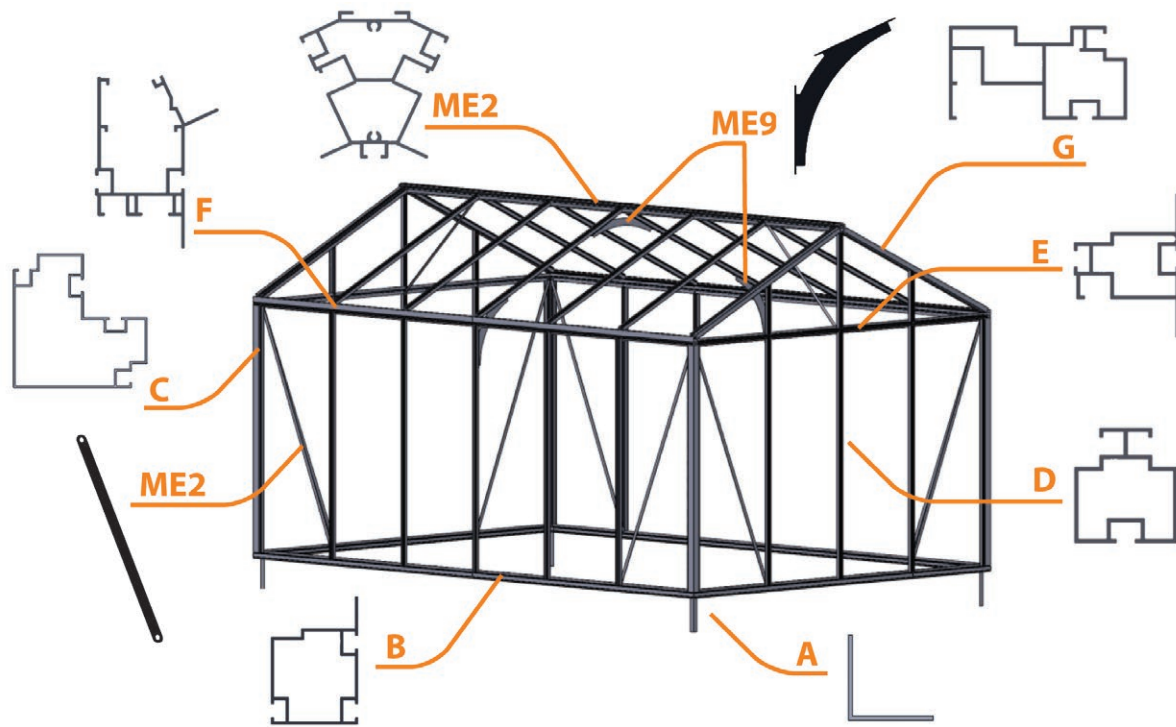



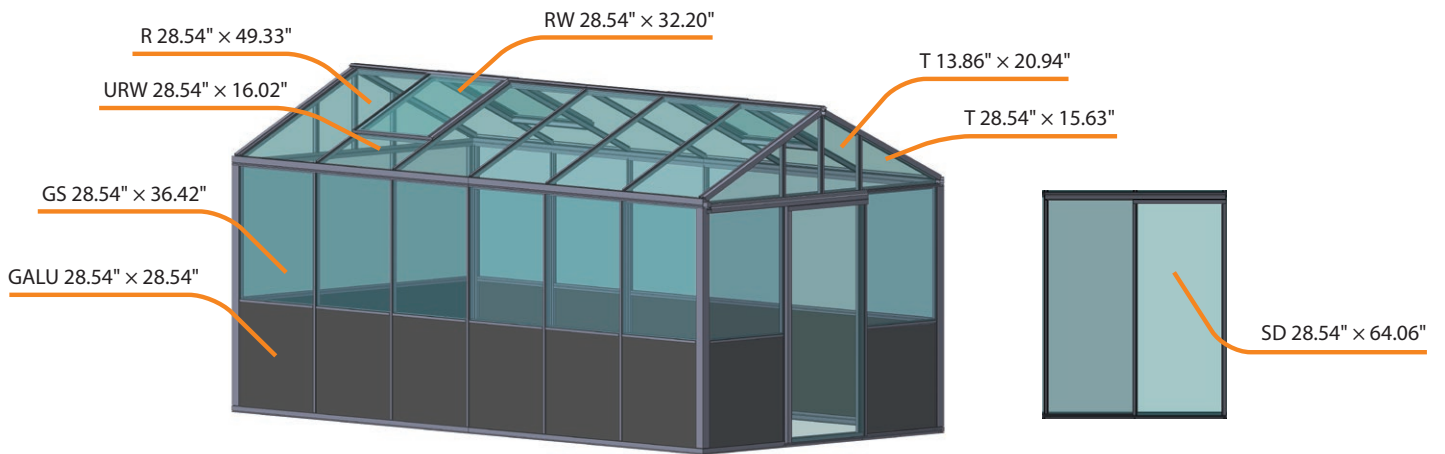



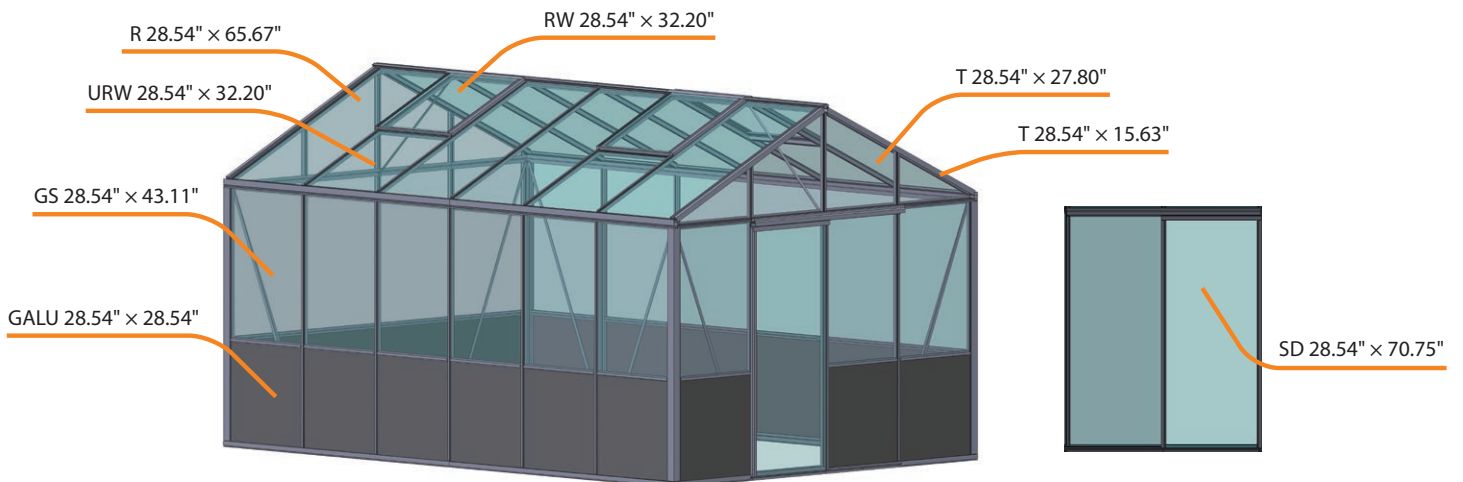













Classic Premium Prestige glazing 92.52"





















Classic Premium Prestige glazing 121.97" / 151.57"







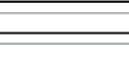



















































Part description, code and size			92,60x63,23	92,60x92,60	92,60x121,97	92,60x151,34	92,60x180,71	92,60x210,08	92,60x239,45		
	B1	63,23	2								
	B2	90			2	2	2	2	2		
	B3	32			2			2			
	B5	92,6	2	4	2	2	2	2	2		
	B6	61,34				2			2		
	B7	90,71					2				
	B8	88,11						2	2		
	C2	65,35	4	4	4	4	4	4	4		
	D2	65,35	6	8	10	12	14	16	18		
	I6	48,78	2	4	6	8	10	12	14		
	I2	15	2	2	2	2	2	2	2		
	I5	21	2	2	2	2	2	2	2		
	I4	15	2	2	2	2	2	2	2		
	I7	28	10	12	14	17	20	23	25		
	E4	89,37	2	2	2	2	2	2	2		
	F1	63,15	2								
	F2	92,52		2							
	F3	90			2	2	2	2	2		
	F4	31,93			2			2			
	F6	61,3				2			2		
	F7	90,67					2				
	F8	88,11						2	2		
	G2	48,78	4	4	4	4	4	4	4		
	K1	63,15	1								
	K2	92,52		1							
	K3	90			1	1	1	1	1		
	K4	31,93			1			1			
	K6	61,3				1			1		
	K7	90,67					1				
	K8	88,11						1	1		
	L1	30,63	1	1	1	2	3	4	4		
	L2	32,52	2	2	2	4	6	8	8		
	L3	30,63	1	1	1	2	3	4	4		
	M1	30,63	1	1	1	1	1	1	1		
	M6	64,41	2	2	2	2	2	2	2		
	M3	30,63	1	1	1	1	1	1	1		
	M4	60,24	1	1	1	1	1	1	1		
	M5	60,24	1	1	1	1	1	1	1		
	M7	65	2	2	2	2	2	2	2		
	S1	11,81	0	0	11	11	11	22	22		
	ME11	37,6	2	2	2	2	2	2	2		
	ME10	71,85	8	8	8	8	8	8	8		
	ME4	58,07	0	0	1	2	0	0	0		
	ME9	11.81 x 11.81	0	0	0	0	2 sets	2 sets	3 sets		
	ME5	1.38 x 1.38	8	8	8	10	12	14	14		
	ME6	2.36 x 2.36	2	2	2	4	6	8	8		
	ME7	23,5	1	1	1	2	3	4	4		
	ME8	2	8	12	16	20	24	28	32		
	A1	0,6x0,6x28	4	4	4	4	4	4	4		
	A3	1.38 x 1.38 x 11.81	1	1	1	1	1	1	1		
	A2	0.59 x 0.59 x 64.41	1 if double doors								
	S2	2.76 x 0.55 x 0.08	1 if double doors								
	Glazing rubber (ft)		290	340	390	440	490	540	590		
	Brush strip (in)		130	130	130	130	130	130	130		























	Down pipe bend 90° - Ø1,38 inch	2	2	2	2	2	2	2
	Sliding roller	2	2	2	2	2	2	2
	Bolts 6x12	160	170	190	220	260	280	300
	Bolts 6x30	2	2	2	4	6	8	8
	Nuts 6x1	160	170	190	220	260	280	300
	Bolts, washer, 2 nuts 7x20	1	1	1	2	3	4	4
	Bolts, washer, nuts 10x20	2	2	2	2	2	2	2
	Tapping screws 4,8x25	8	8	8	12	16	20	20
	Tapping screws 4,8x19	8	8	8	8	8	8	8
	Hexagon socket screws	0	0	44	44	68	88	88
	Nut caps	165	175	195	225	265	285	305
	Gutter end incl. downpipe	2	2	2	2	2	2	2
	Gutter end	2	2	2	2	2	2	2
	Ridge end	2	2	2	2	2	2	2
	Railends (L) sliding door	1	1	1	1	1	1	1
	Railends (R) sliding door	1	1	1	1	1	1	1
	PVC piece gable	4	4	4	4	4	4	4
	Plactic cap 12	4	6	8	10	12	14	16
	ME6 Plastic	10	10	10	10	10	10	10
Glass								
	Sliding door 28,54 x 64,06 inches	1	1	1	1	1	1	1
	Roof 28,54 x 65,55 inches	3	5	7	8	9	10	12
	Roof window 28,54 x 32,20 inches	1	1	1	2	3	4	4
	Underneath roof window 28,54 x 16,02 inches	1	1	1	2	3	4	4
	Triangle 28,54 x 15,63 inches	4	4	4	4	4	4	4
	Triangle 13,86 x 20,95 inches	4	4	4	4	4	4	4
	Gable Side 28,54 x 36,42 inches	9	11	13	15	17	19	21
	Gable Aluminium 28,54 x 28,54 inches	9	11	13	15	17	19	21

CLASSIFICATION OF PARTS*

Part description, code and size			122x63,23	122x92,60	122x122	122x151,34	122x180,71	122x210	122x239,45
		mm							
	B1	63,23	2						
	B2	90	2	2	4	4	4	4	4
	B3	32	2	2	4	2	2	4	2
	B5	92,6		2					
	B6	61,34				2			2
	B7	90,71					2		
	B8	88,11						2	2
	C1	72	4	4	4	4	4	4	4
	D1	72	8	10	12	14	16	18	20
	I1	65	2	4	6	8	10	12	14
	I2	14,92	2	2	2	2	2	2	2
	I3	27,8	2	2	2	2	2	2	2
	I4	14,92	2	2	2	2	2	2	2
	I7	28	12	14	16	19	22	25	27
		E1	88,39	2	2	2	2	2	2
E2		30,35	2	2	2	2	2	2	2
	F1	63,15	2						
	F2	92,52		2					
	F3	90			2	2	2	2	2
	F4	31,93			2			2	
	F6	61,3				2			2
	F7	90,67					2		
	F8	88,11						2	2
		G1	65	4	4	4	4	4	4
	K1	63,15	1						
	K2	92,52		1					
	K3	90			1	1	1	1	1
	K4	31,93			1			1	
	K6	61,3				1			1
	K7	90,67					1		
	K8	88,11						1	1
		L1	30,63	1	1	1	2	3	4
	L2	32,52	2	2	2	4	6	8	8
	L3	30,63	1	1	1	2	3	4	4
	M1	30,63	1	1	1	1	1	1	1
	M2	71,1	2	2	2	2	2	2	2
	M3	30,63	1	1	1	1	1	1	1
	M4	60,24	1	1	1	1	1	1	1
	M5	60,24	1	1	1	1	1	1	1
	M7	71,65	2	2	2	2	2	2	2
	S1	11,81	6	6	17	17	17	28	28
	ME1	41,85	2	2	2	2	2	2	2
	ME2	78	8	8	8	8	8	8	8
	ME4	58,07	0	0	1	2	0	0	0
	ME9	11.81 x 11.81	0	0	0	0	2 sets	2 sets	3 sets

	ME5	1.38 x 1.38	8	8	8	10	12	14	14
	ME6	2.36 x 2.36	2	2	2	4	6	8	8
	ME7	23,5	1	1	1	2	3	4	4
	ME8	2	8	12	16	20	24	28	32
	A1	1.38 x 1.38 x 11.81	4	4	4	4	4	4	4
	A3	0,6x0,6x28	1	1	1	1	1	1	1
	A2	0.59 x 0.59 x 71.1	1 if double doors						
	S2	2.76 x 0.55 x 0.08	1 if double doors						
	Glazing rubber (ft)		360	430	475	541	590	655	720
	Brush strip (in)		142	142	142	142	142	142	142
	Down pipe bend 90° - Ø1,38 in		2	2	2	2	2	2	2
	Sliding roller		2	2	2	2	2	2	2
	Bolts 6x12		160	170	190	220	260	280	300
	Bolts 6x30		2	2	2	4	6	8	8
	Nuts 6x1		160	170	190	220	260	280	300
	Bolts, washer, 2 nuts 7x20		1	1	1	2	3	4	4
	Bolts, washer, nuts 10x20		2	2	2	2	2	2	2
	Tapping screws 4,8x25		8	8	8	12	16	20	20
	Tapping screws 4,8x19		8	8	8	8	8	8	8
	Hexagon socket screws		24	24	68	68	68	112	112
	Nut caps		165	175	195	225	265	285	305
	Gutter end incl. downpipe		2	2	2	2	2	2	2
	Gutter end		2	2	2	2	2	2	2
	Ridge end		2	2	2	2	2	2	2
	Railends (L) sliding door		1	1	1	1	1	1	1
	Railends (R) sliding door		1	1	1	1	1	1	1
	PVC piece gable		4	4	4	4	4	4	4
	Plastic cap 12		6	8	10	12	14	16	18
	ME6 Plastic		10	10	10	10	10	10	10
Glass									
Sliding door 28,54 x 70,75 in			1	1	1	1	1	1	1
Roof 28,54 x 65,67 in			3	5	7	8	9	10	12
Roof window / Underneath roof window 28,54 x 32,20 in			2	2	2	4	6	8	8
Triangle 28,54 x 27,80 in			4	4	4	4	4	4	4
Triangle 28,54 x 15,53 in			4	4	4	4	4	4	4
Gable Side 28,54 x 43,11 in			11	13	15	17	19	21	23
Gable Aluminium 28,54 x 28,54 in			11	13	15	17	19	21	23

Part description, code and size			151,34x63,23	151,34x92,60	151,34x122	151,34x151,34	151,34x180,7	151,34x210	151,34x239,45		
		mm									
	B1	63,23	2								
	B2	90	2	2	4	4	4	4	4		
	B3	32			2			2			
	B5	92,6		2							
	B6	61,34	2	2	2	4	2	2	4		
	B7	90,71					2				
B8	88,11						2	2			
	C1	72	4	4	4	4	4	4	4		
	D1	72	10	12	14	16	18	20	22		
	I2062	81,18	2	4	6	8	10	12	14		
	I2	14,92	2	2	2	2	2	2	2		
	I728.1	28,66	2	2	2	2	2	2	2		
	I728.2	28,66	2	2	2	2	2	2	2		
	I4	14,92	2	2	2	2	2	2	2		
	I881	34,69	2	2	2	2	2	2	2		
	I7	28	19	18	20	23	26	29	31		
	E1.1	88,39	2	2	2	2	2	2	2		
	E13	59,72	2	2	2	2	2	2	2		
	F1	63,15	2								
	F2	92,52		2							
	F3	90			2	2	2	2	2		
	F4	31,93			2			2			
	F6	61,3				2			2		
	F7	90,67					2				
	F8	88,11						2	2		
	G2062	81,18	4	4	4	4	4	4	4		
	K1	63,15	1								
	K2	92,52		1							
	K3	90			1	1	1	1	1		
	K4	31,93			1			1			
	K6	61,3				1			1		
	K7	90,67					1				
	K8	88,11						1	1		
	L1	30,63	1	1	2	2	3	4	4		
	L2	32,52	2	2	4	4	6	8	8		
	L3	30,63	1	1	2	2	3	4	4		
	M1	30,63	1	1	1	1	1	1	1		
	M2	71,1	2	2	2	2	2	2	2		
	M3	30,63	1	1	1	1	1	1	1		
	M4	60,24	1	1	1	1	1	1	1		
	M5	60,24	1	1	1	1	1	1	1		
	M7	71,65	2	2	2	2	2	2	2		
	S1	11,81	6	6	17	17	17	28	28		
	ME1	41,85	2	2	2	2	2	2	2		
	ME2	78	8	8	8	8	8	8	8		
	ME9	11.81 x 11.81	1 set	2 sets	3 sets	4 sets	5 sets	6 sets	7 sets		
	ME5	1.38 x 1.38	12	12	14	14	16	18	18		
	ME6	2.36 x 2.36	2	2	4	4	6	8	8		
	ME7	23,5	1	1	2	2	3	4	4		
	ME8	2	8	12	16	20	24	28	32		
	A1	1.38 x 1.38 x 11.81	4	4	4	4	4	4	4		
	A3	0,6x0,6x28	1	1	1	1	1	1	1		
	A2	0.59 x 0.59 x 71.1	1 if double doors								

	S2	2.76 x 0.55 x 0.08	1 if double doors					
	Glazing rubber (ft)	425	490	555	190	655	720	785
	Brush strip (in)	142	142	142	142	142	142	142
	Down pipe bend 90° - Ø1,38 in	2	2	2	2	2	2	2
	Sliding roller	2	2	2	2	2	2	2
	Bolts 6x12	170	190	220	260	280	300	320
	Bolts 6x30	2	2	4	4	6	8	8
	Nuts 6x1	170	190	220	260	280	300	320
	Bolts, washer, 2 nuts 7x20	1	1	2	2	3	4	4
	Bolts, washer, nuts 10x20	2	2	2	2	2	2	2
	Tapping screws 4,8x25	8	8	12	12	16	20	20
	Tapping screws 4,8x19	8	8	8	8	8	8	8
	Hexagon socket screws	24	24	68	68	68	112	112
	Nut caps	175	195	225	265	285	305	325
	Gutter end incl. downpipe	2	2	2	2	2	2	2
	Gutter end	2	2	2	2	2	2	2
	Ridge end	2	2	2	2	2	2	2
	Railends (L) sliding door	1	1	1	1	1	1	1
	Railends (R) sliding door	1	1	1	1	1	1	1
	PVC piece gable	4	4	4	4	4	4	4
	Plastic cap 12	8	10	12	14	16	18	20
	ME6 Plastic	10	10	10	10	10	10	10
Glass								
	Sliding door 28,54 x 70,75 in	1	1	1	1	1	1	1
	Roof 28,54 x 81,97 in	3	5	6	8	9	10	12
	Roof window 28,54 x 32,2 in	1	1	2	2	3	4	4
	Underneath roof window 28,54 x 48,27 in	1	1	2	2	3	4	4
	Triangle 28,54 x 27,8 in	4	4	4	4	4	4	4
	Triangle 28,54 x 15,63 in	4	4	4	4	4	4	4
	Shape glass 13,62 x 34,64 in	4	4	4	4	4	4	4
	Gable side 28,54 x 43,11 in	13	15	17	19	21	23	25
	Gable Aluminium 28,54 x 28,54 in	13	15	17	19	21	23	25

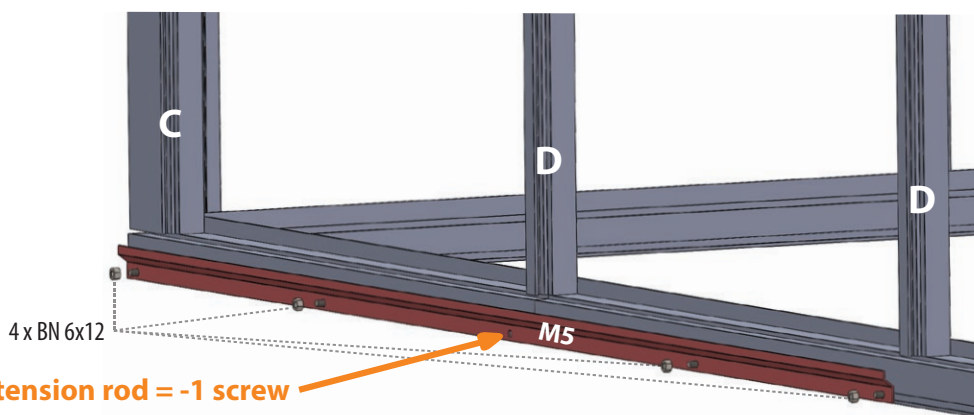
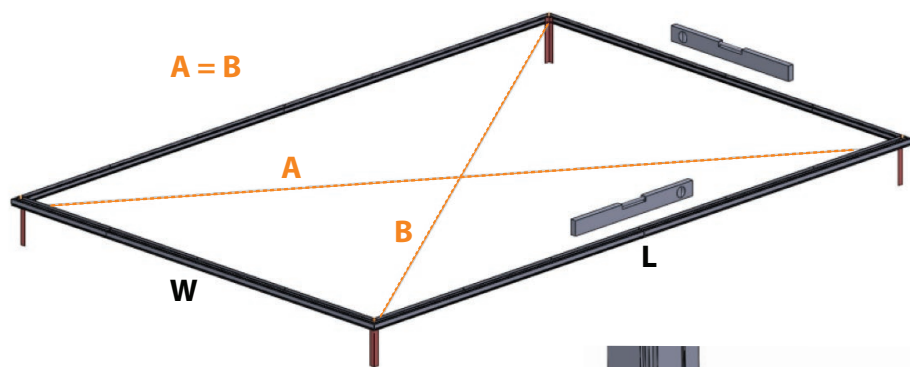
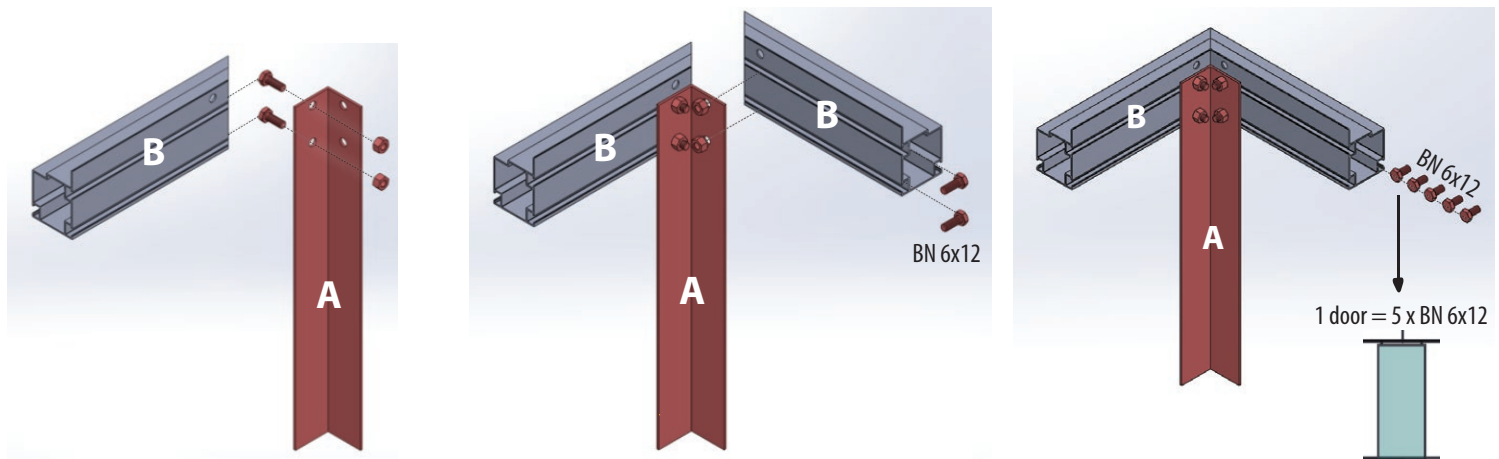

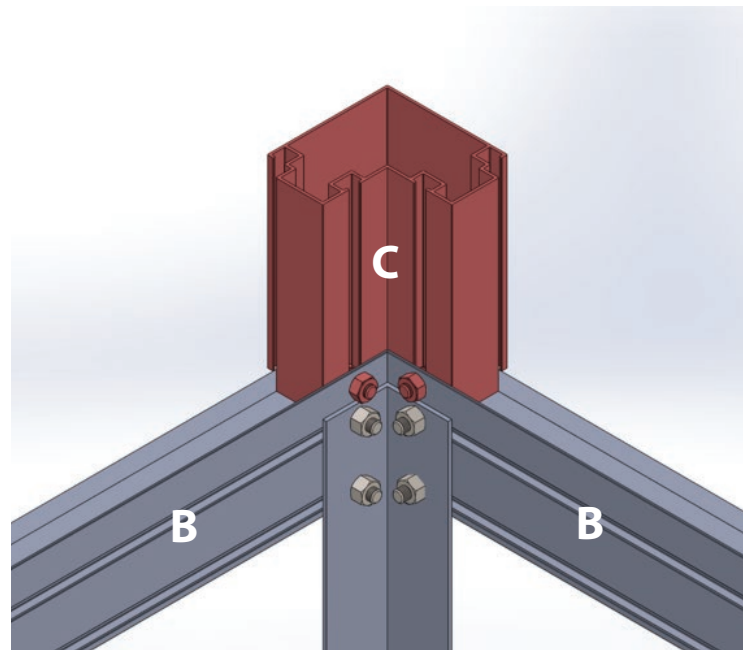
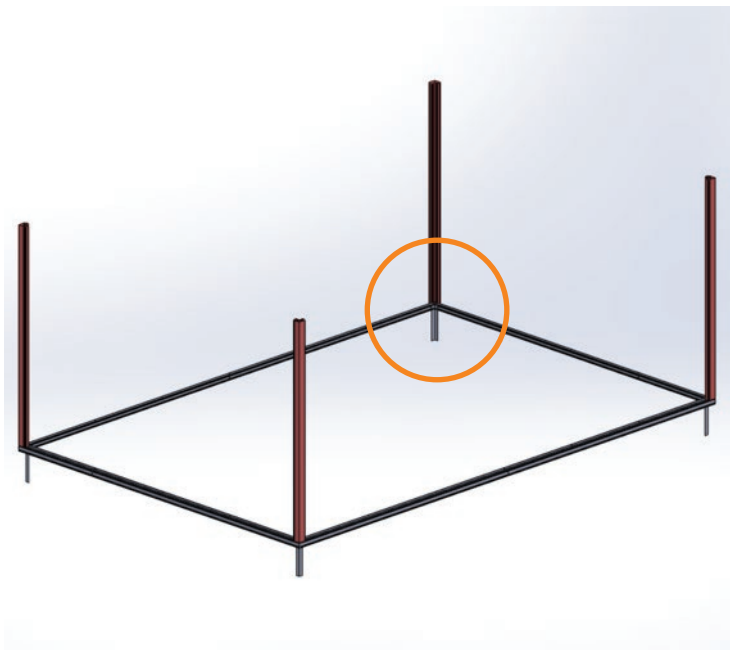
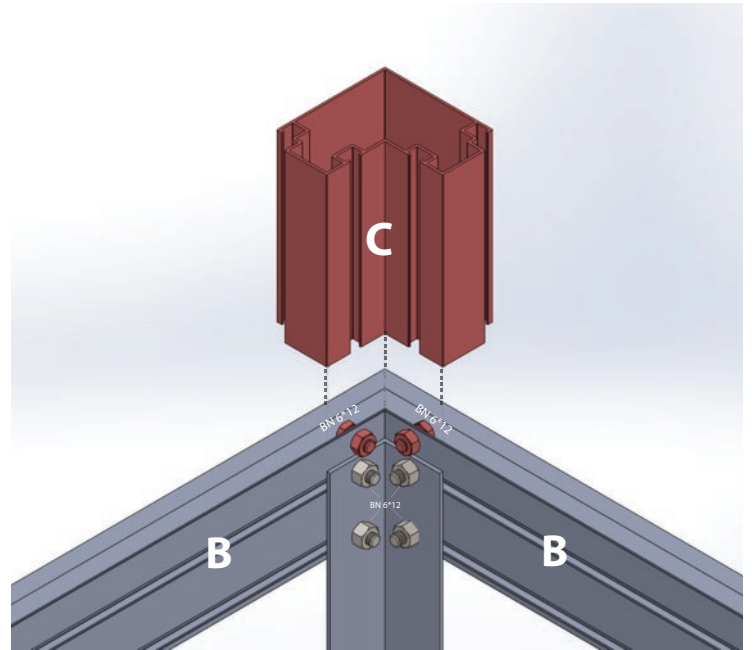
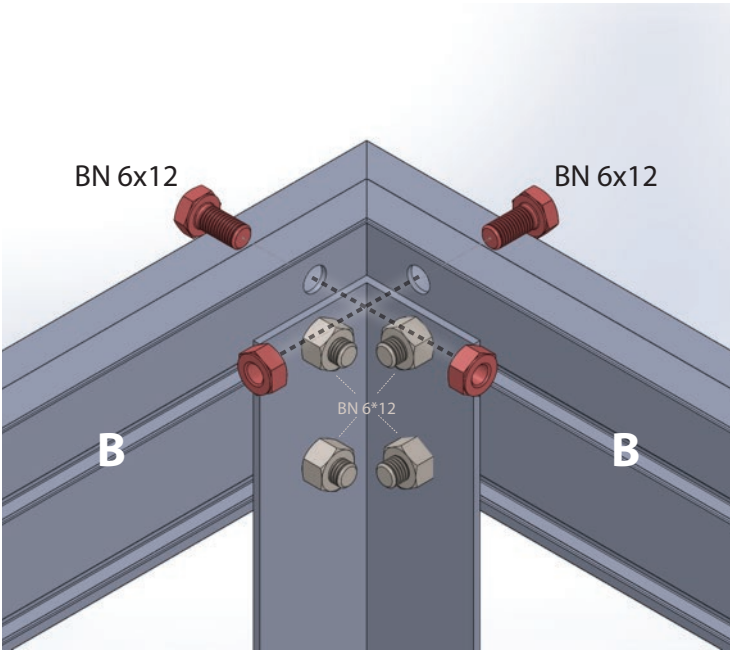

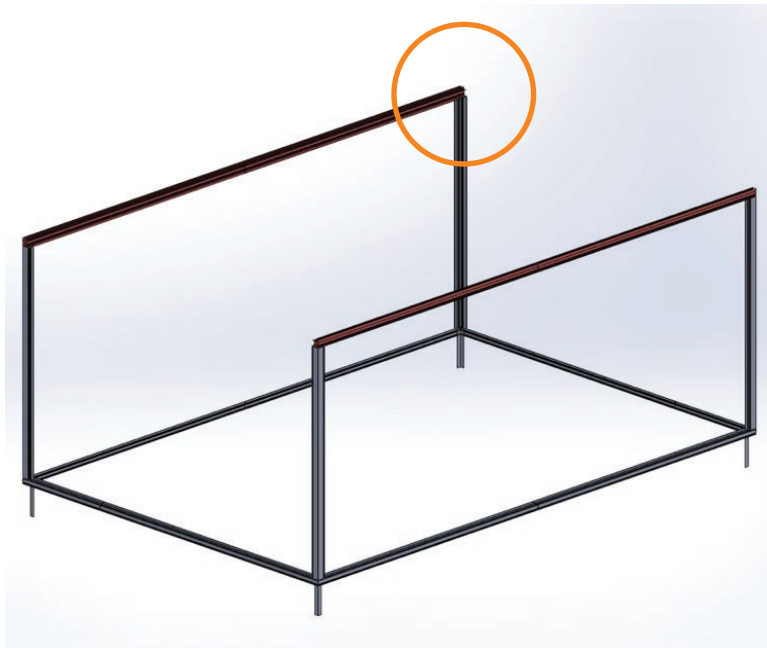
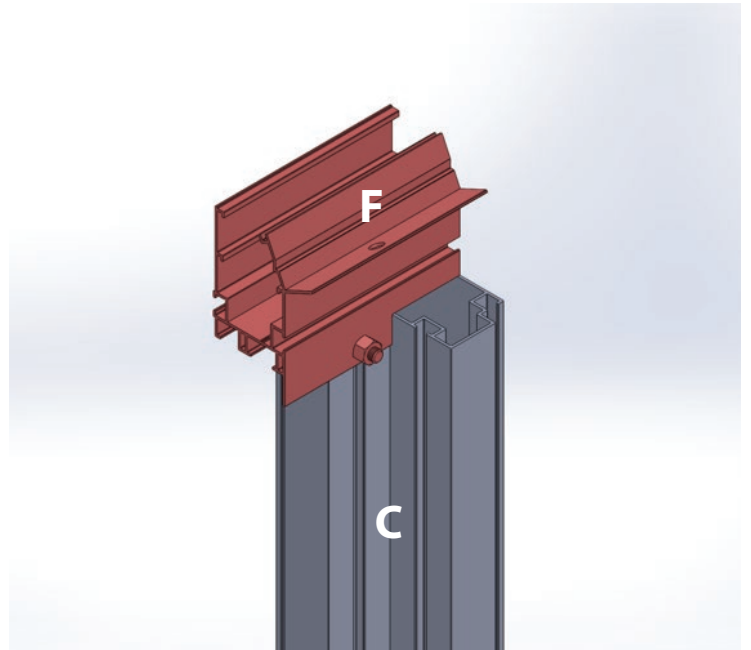
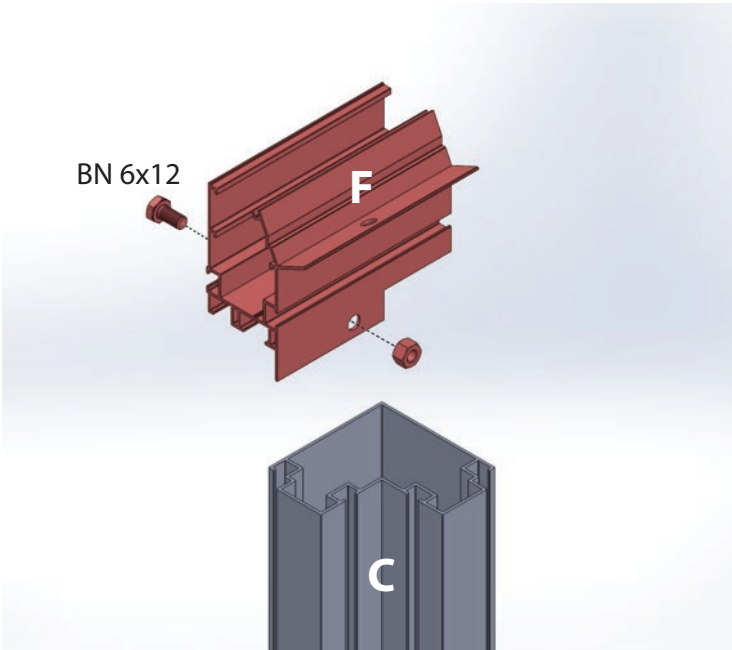

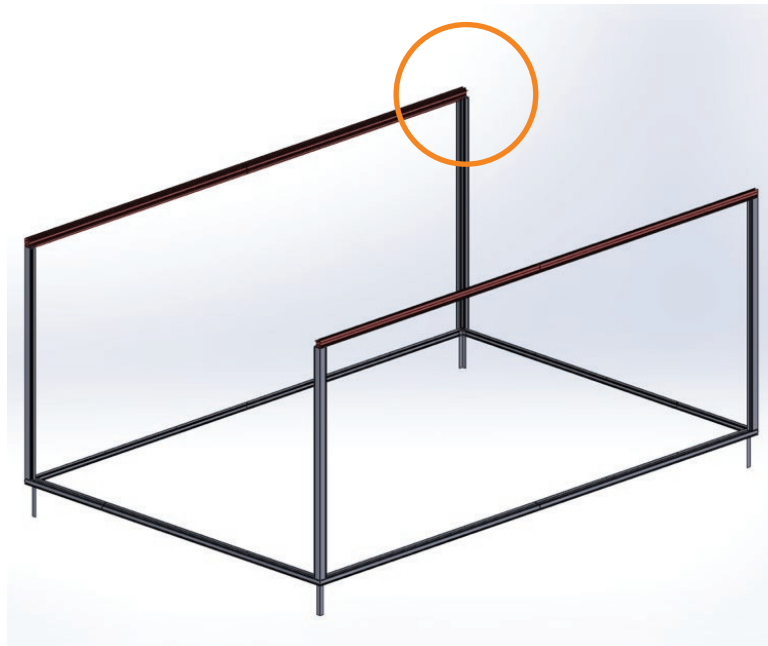
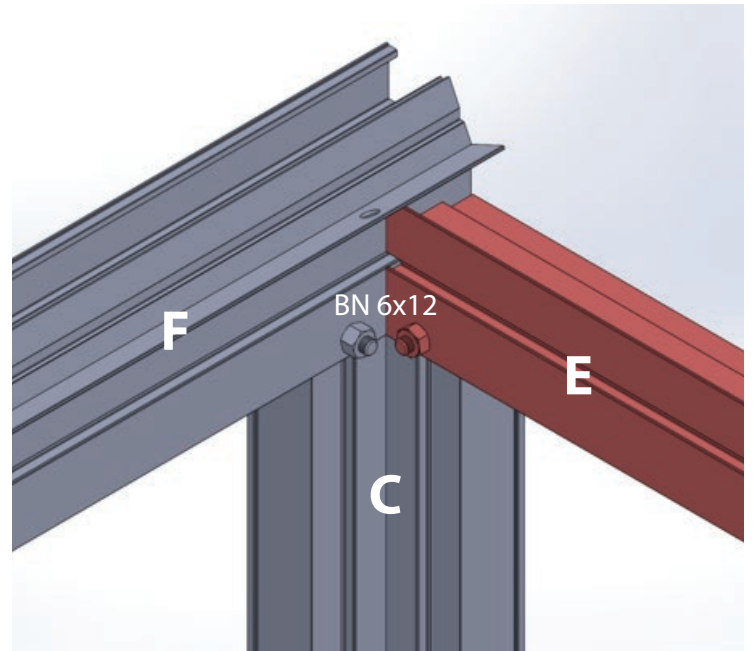
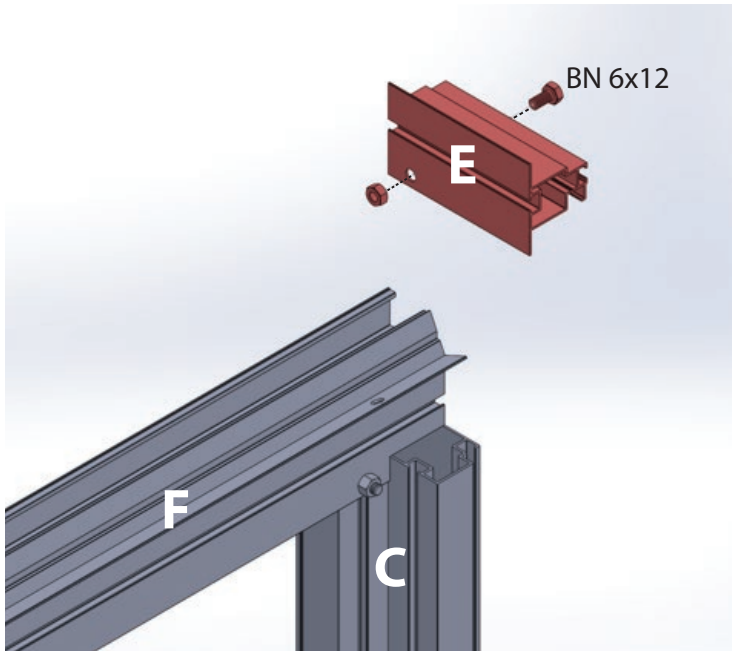

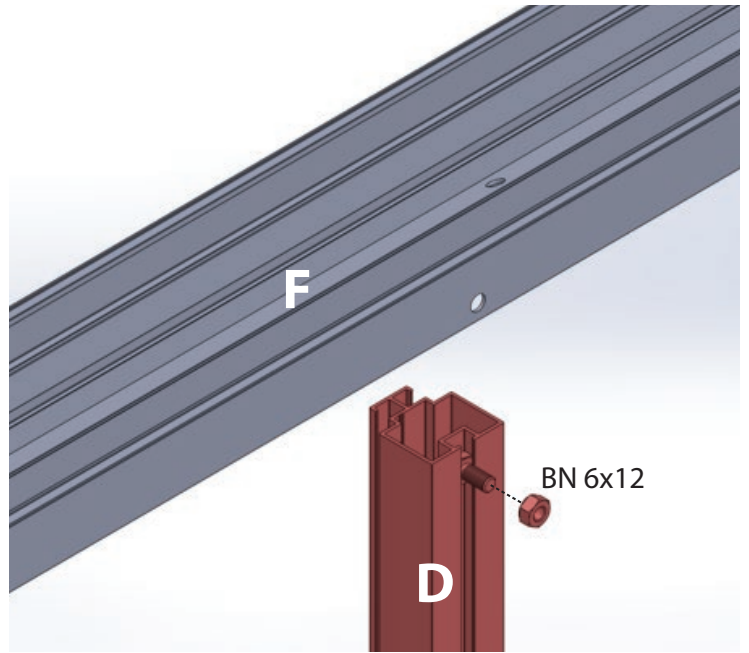
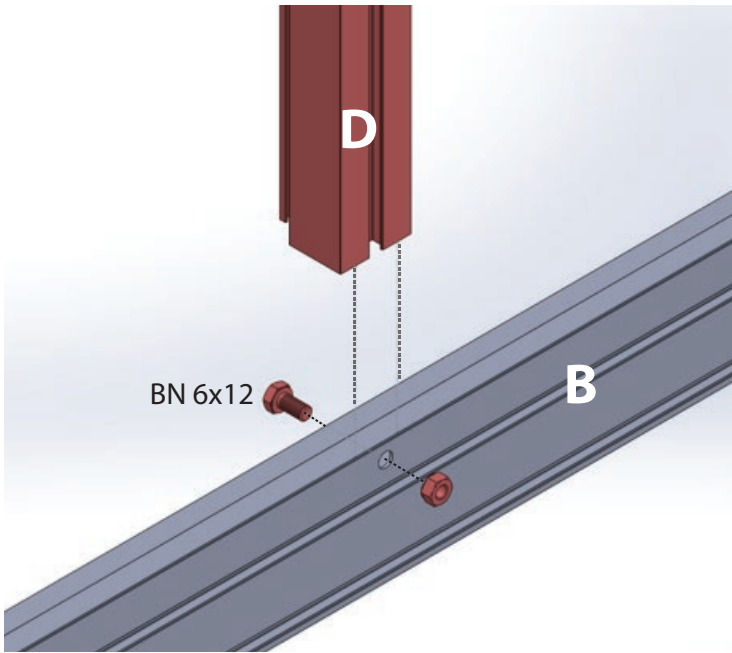

**Middle profile NOT installed if double doors.
Doors can be installed on short and long side.**

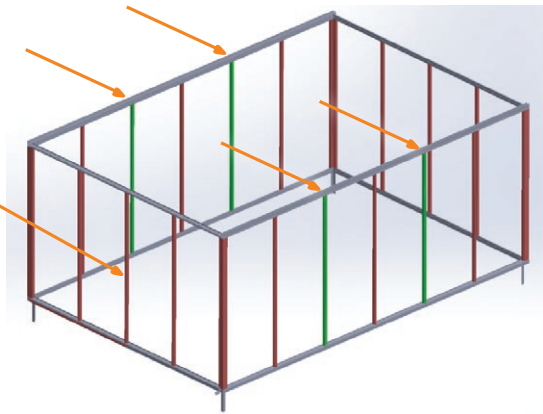

Step 19

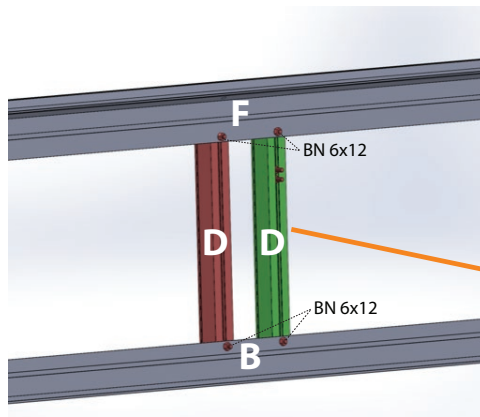

+2x BN 6x12

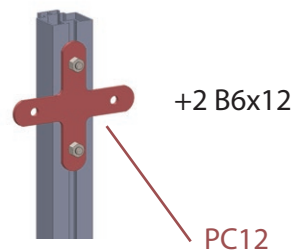
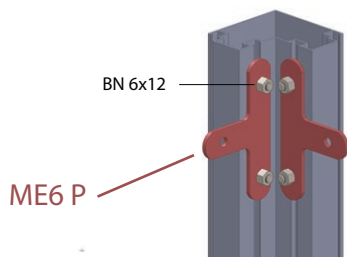

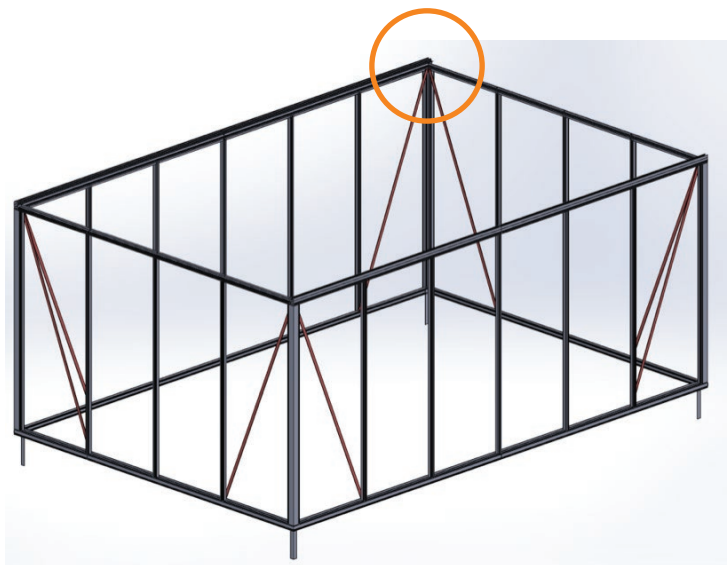
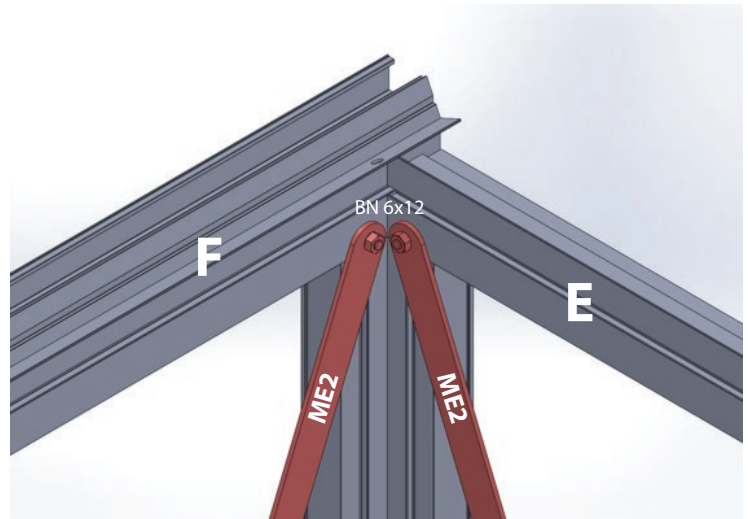
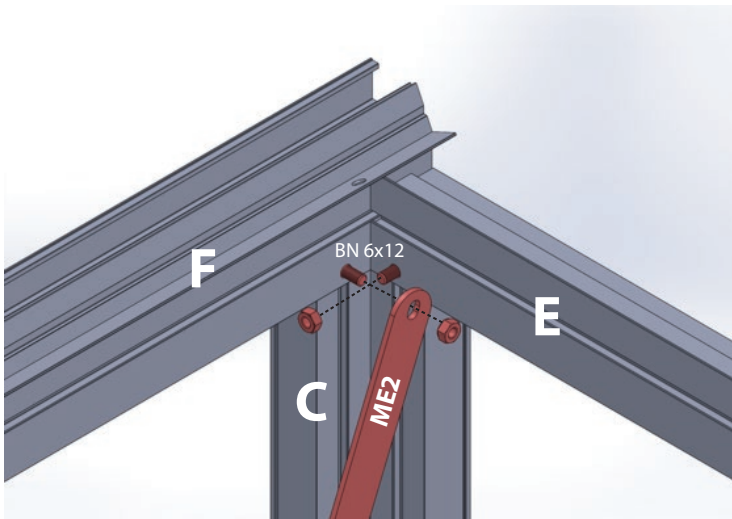
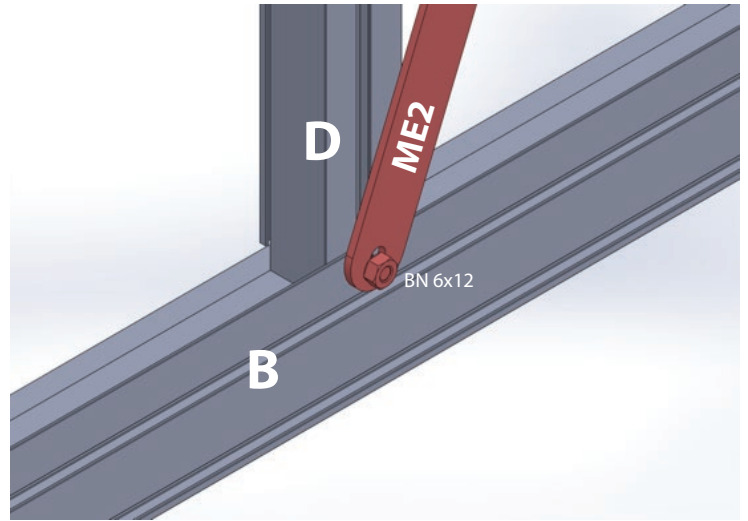
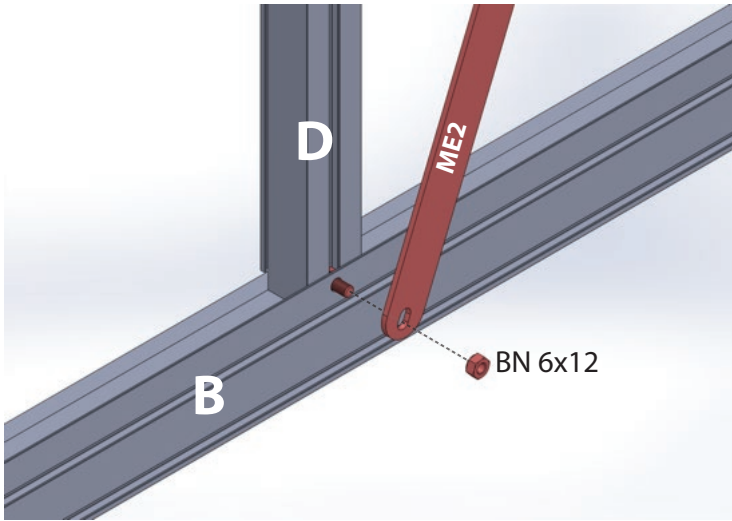

ME10 ← W=2351 mm
 ME2 ← W=3098 mm

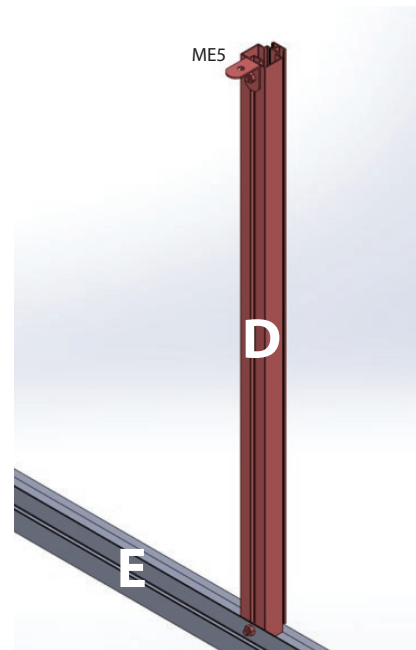
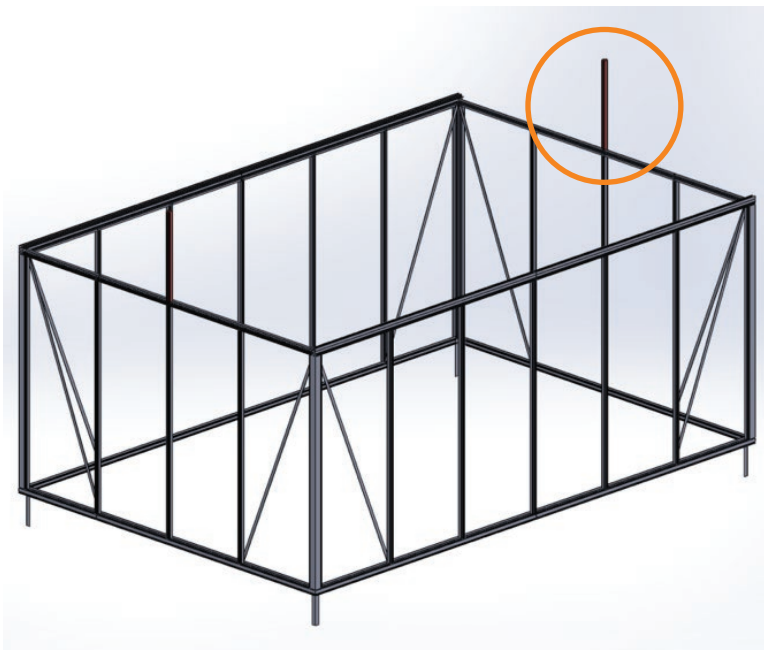
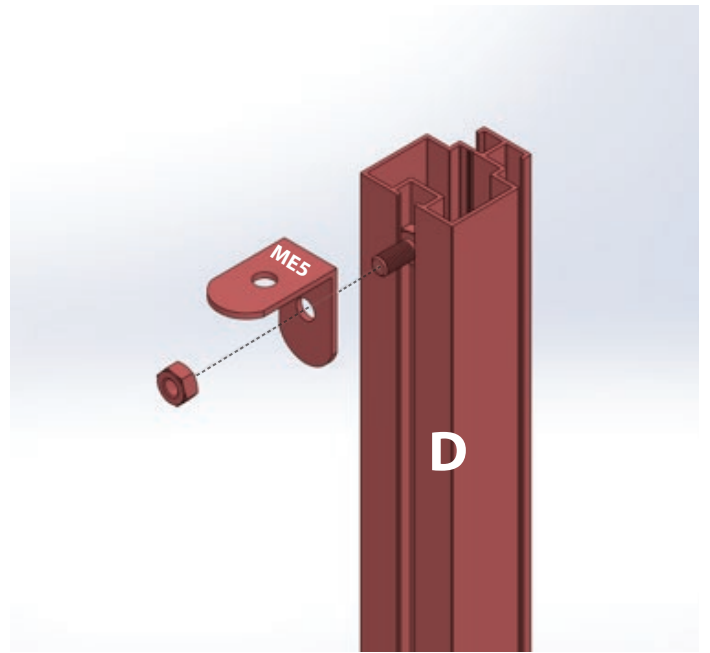
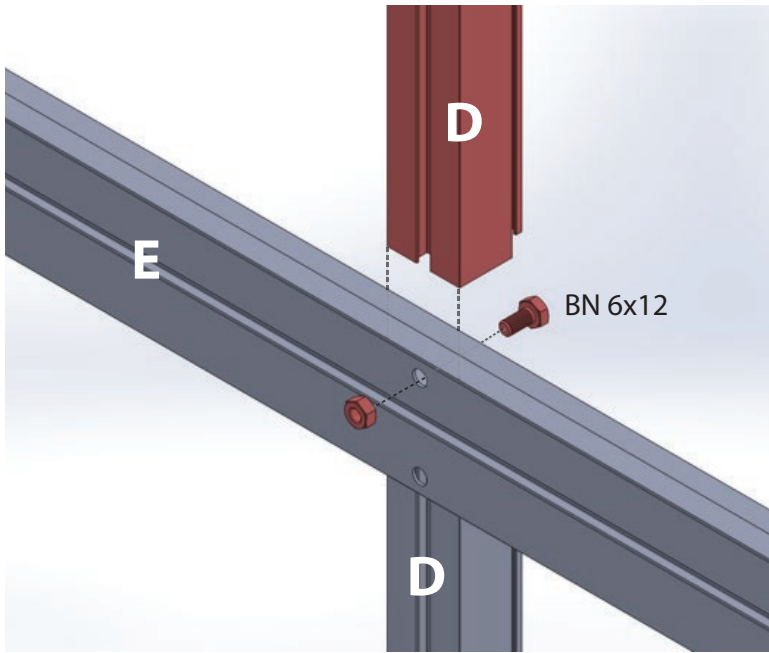

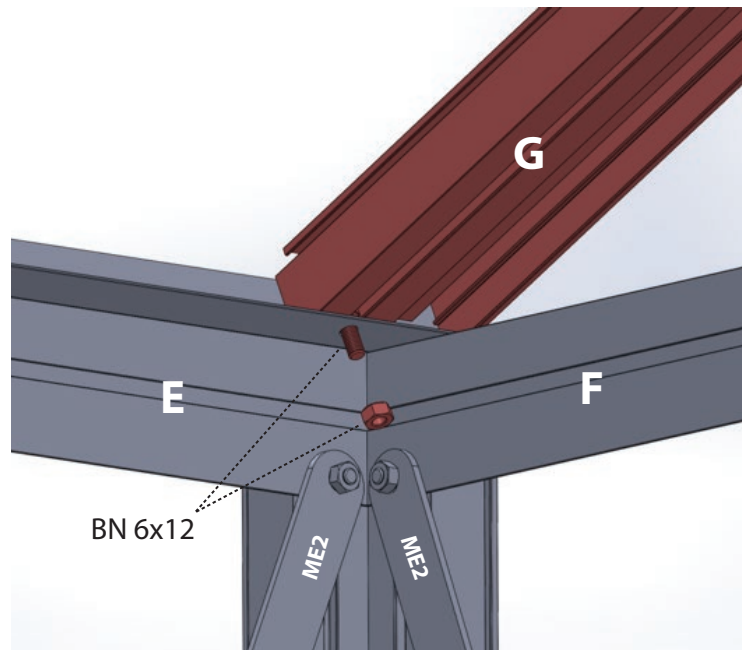
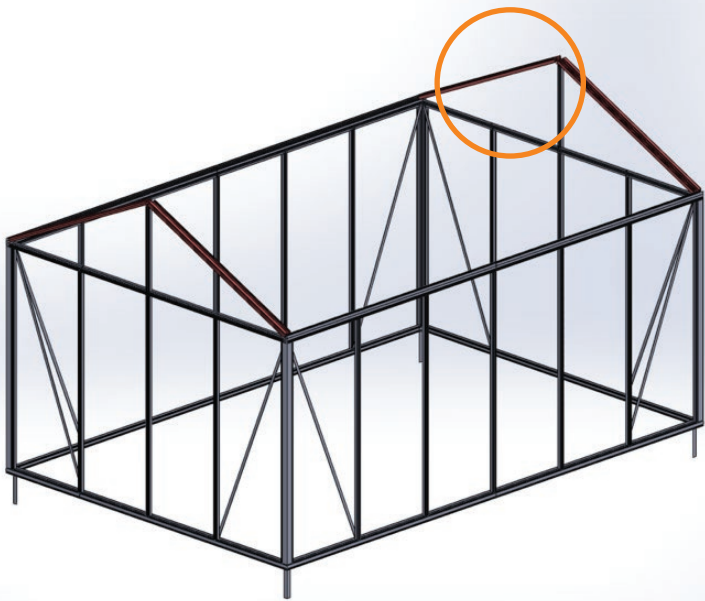
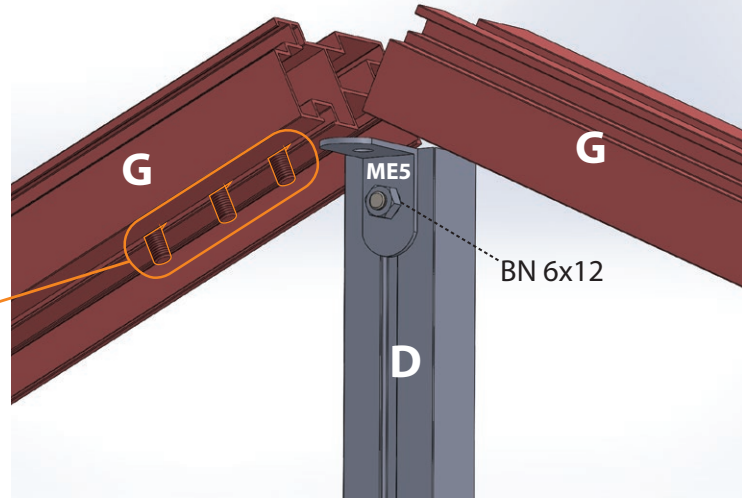
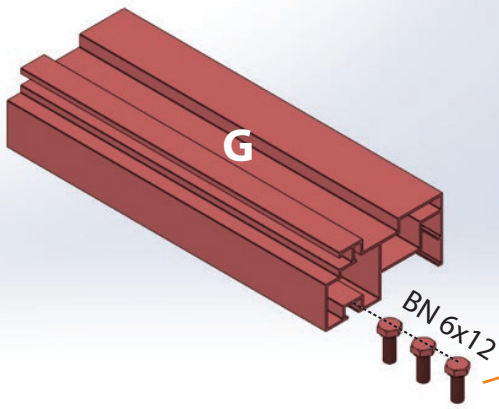

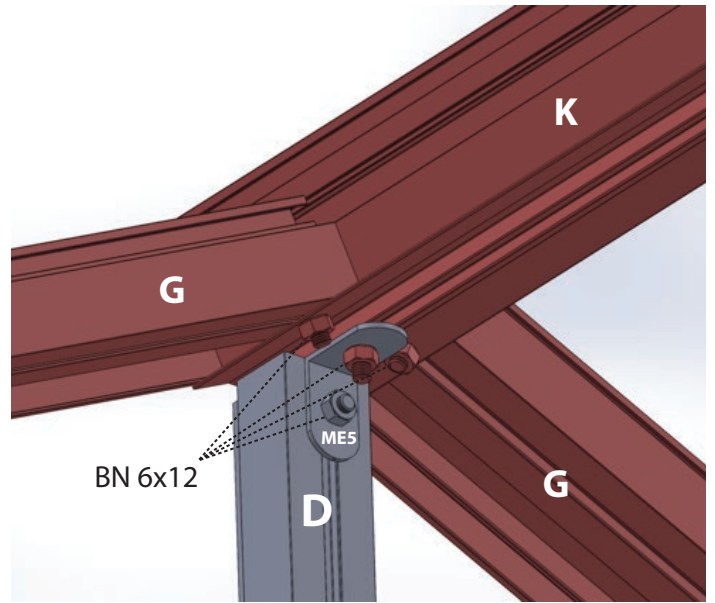
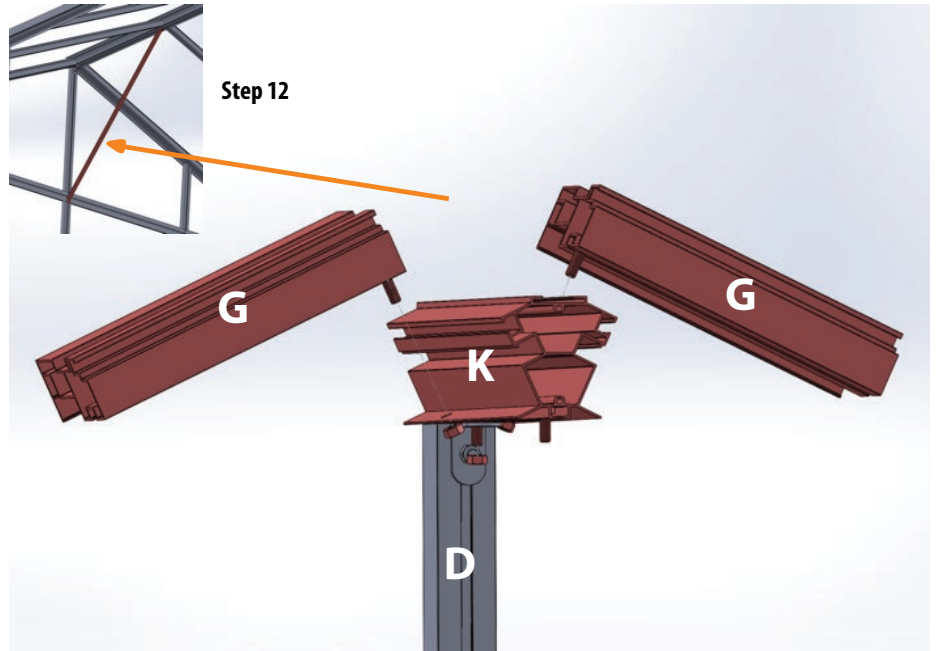
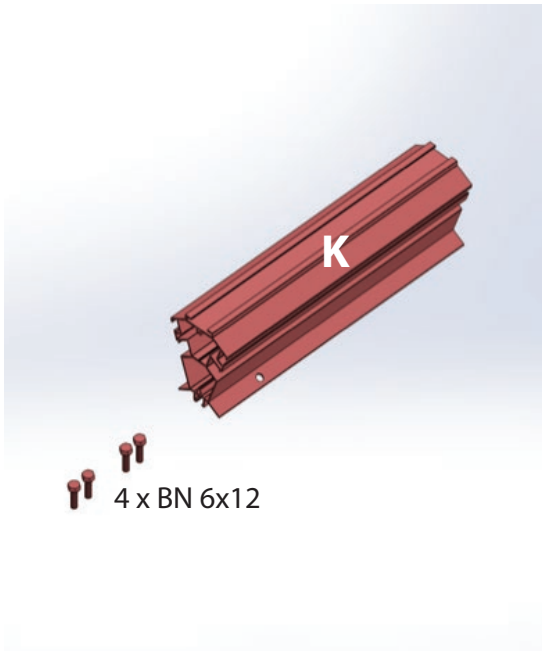

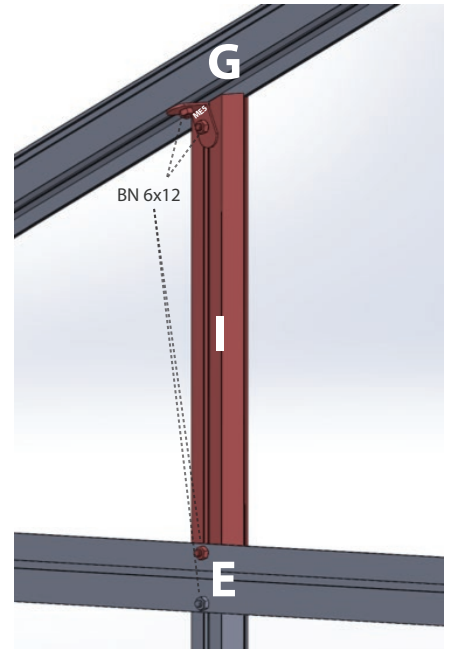
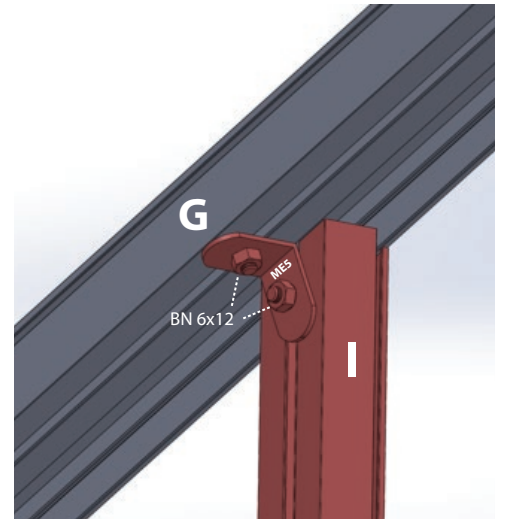
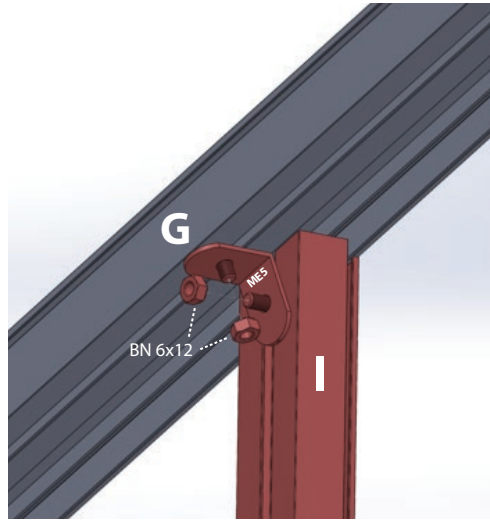
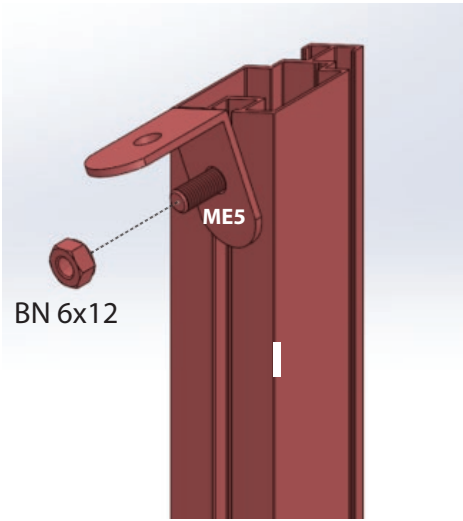

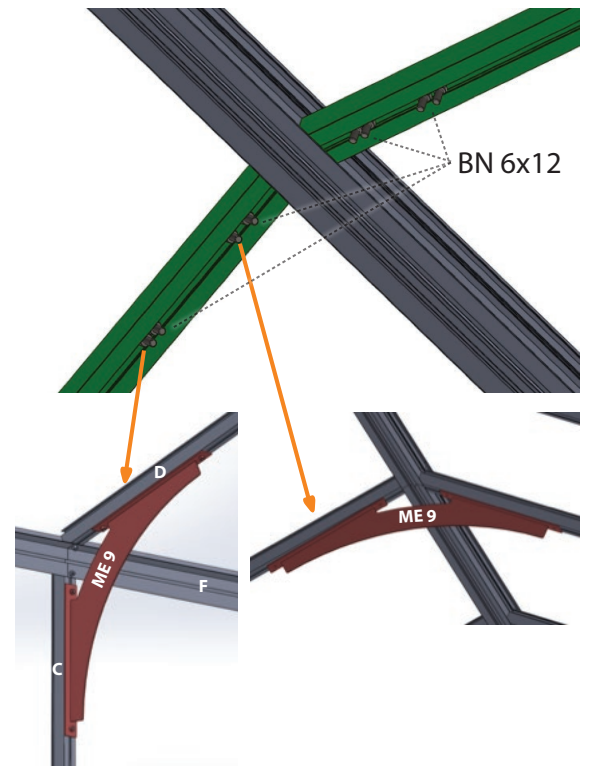

+2x M6x12 for window

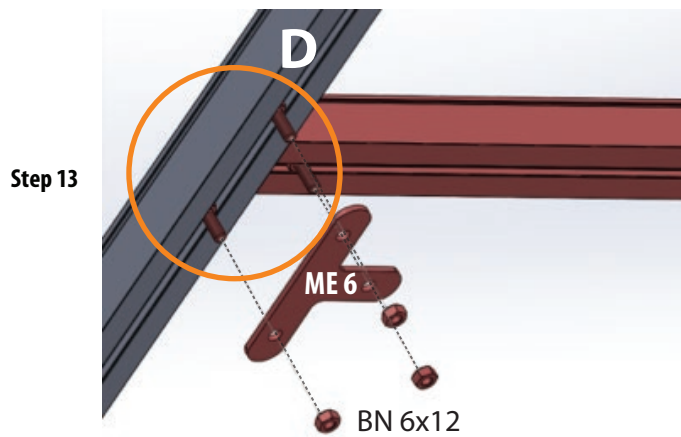

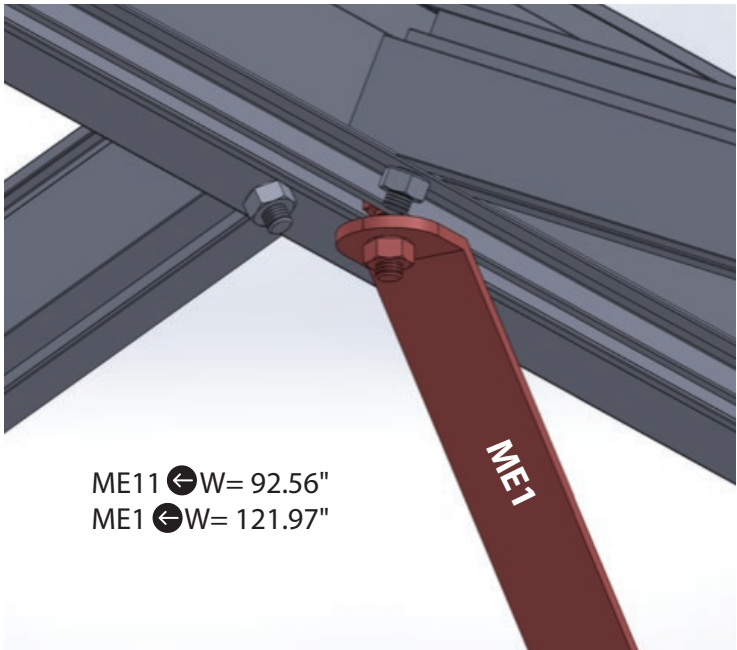
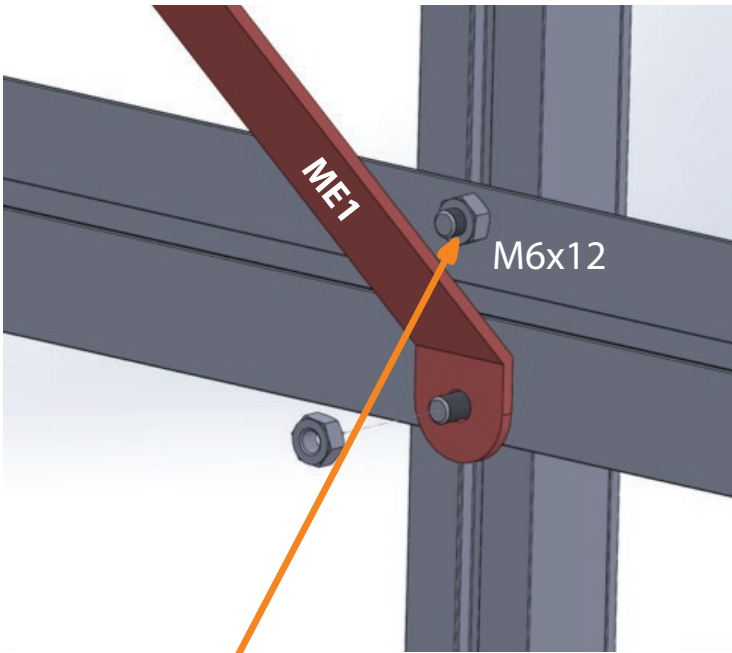

Attach ME1 here

Not used for sizes L = 1606; 2352



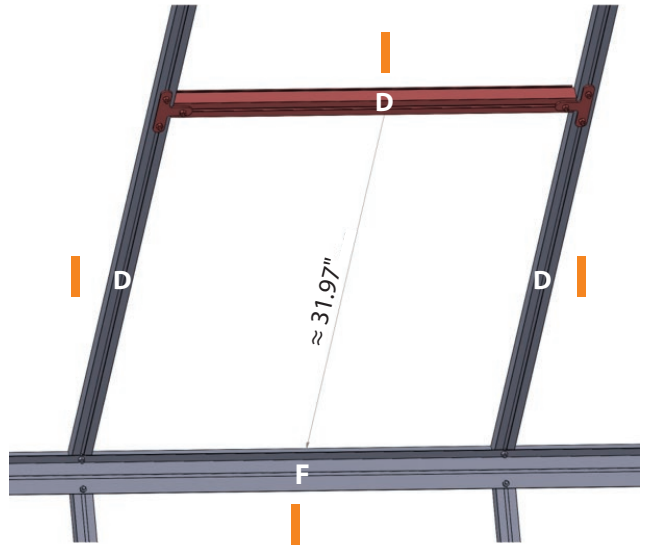
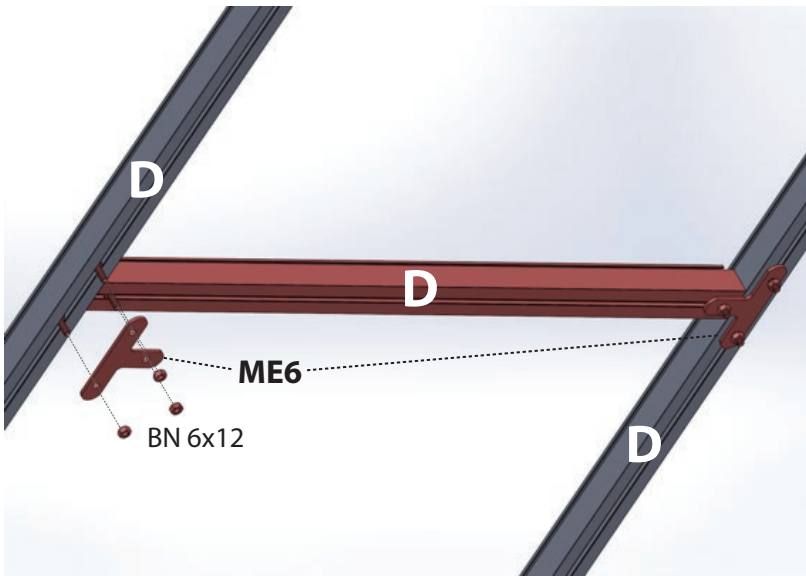
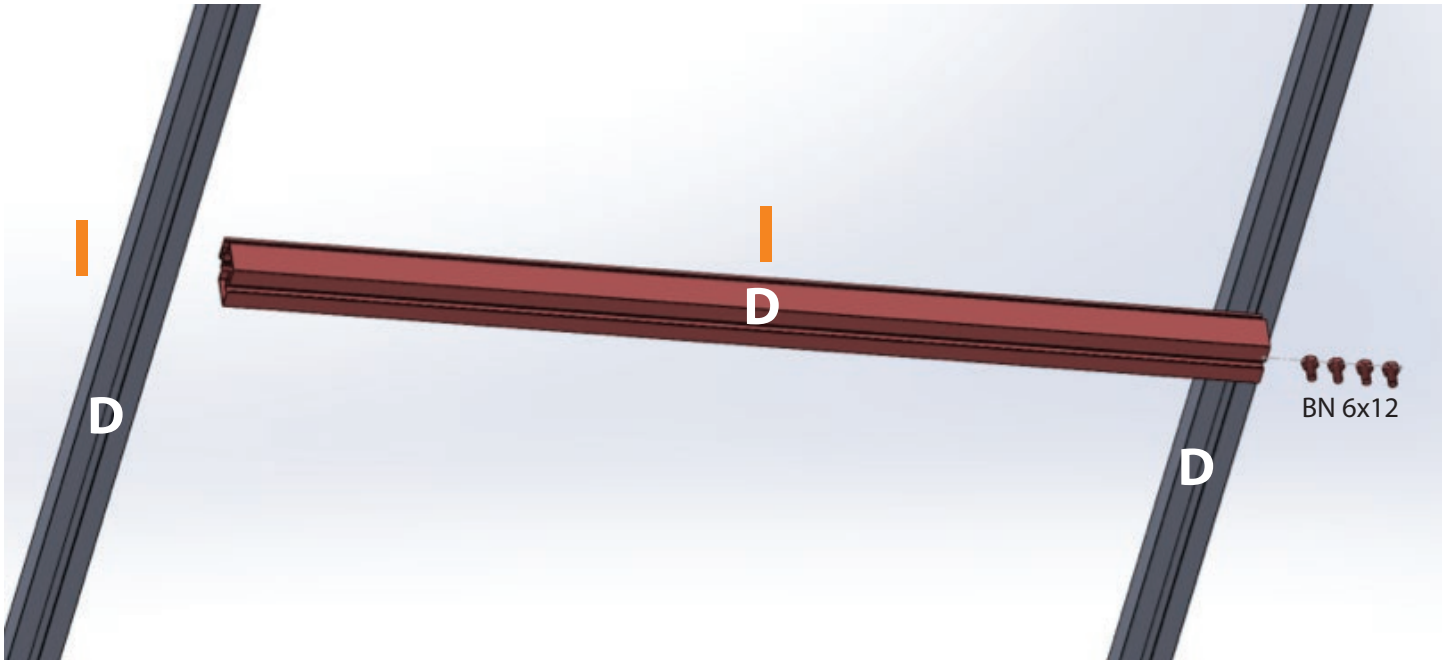

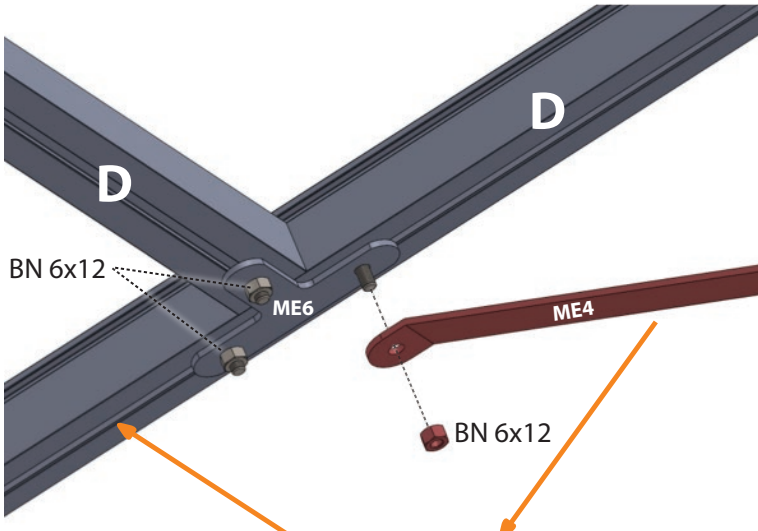
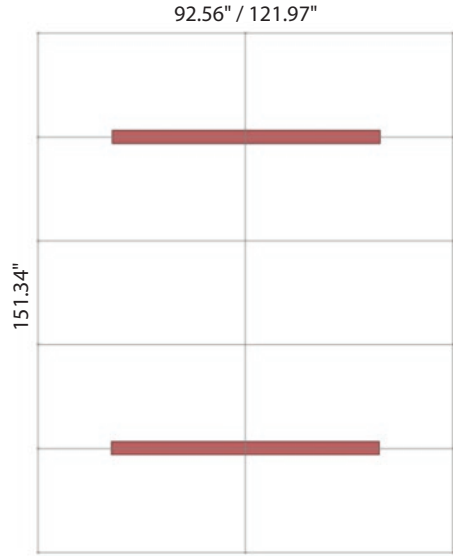
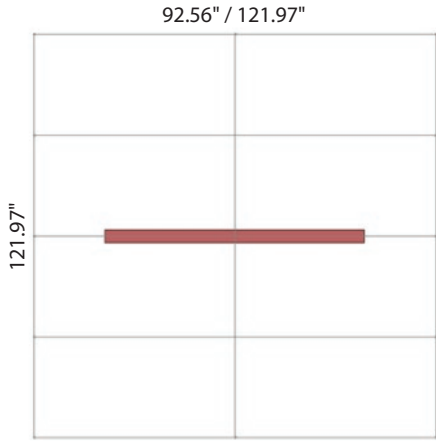

Install ME4 lower with extra screw if your house W=92.56"

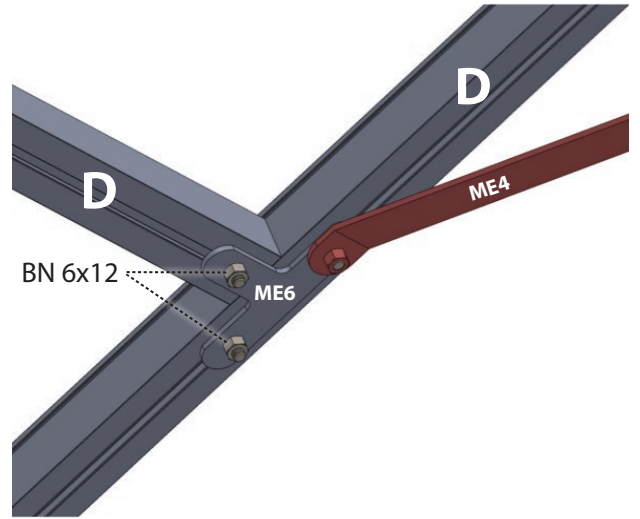

Not used for sizes L = 63.23"; 92.60"

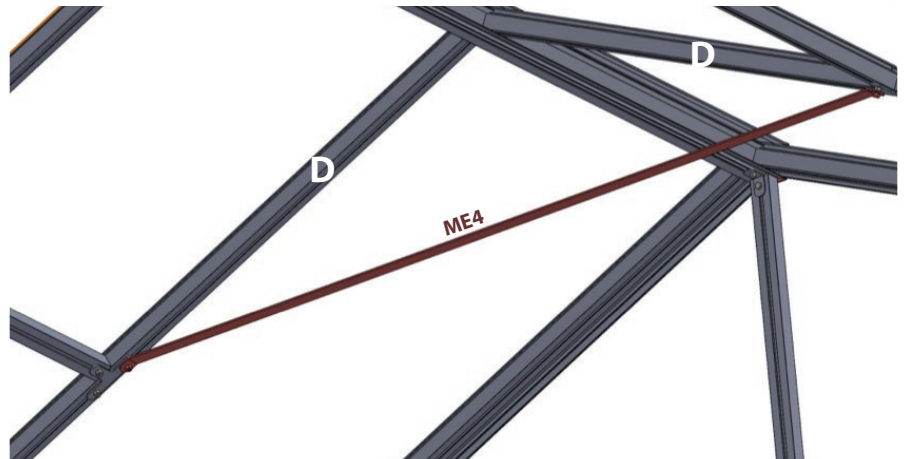

ME9 placement

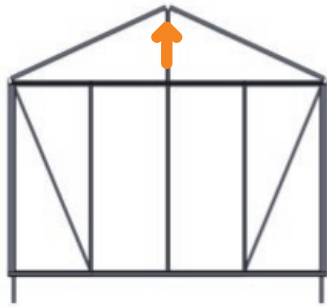
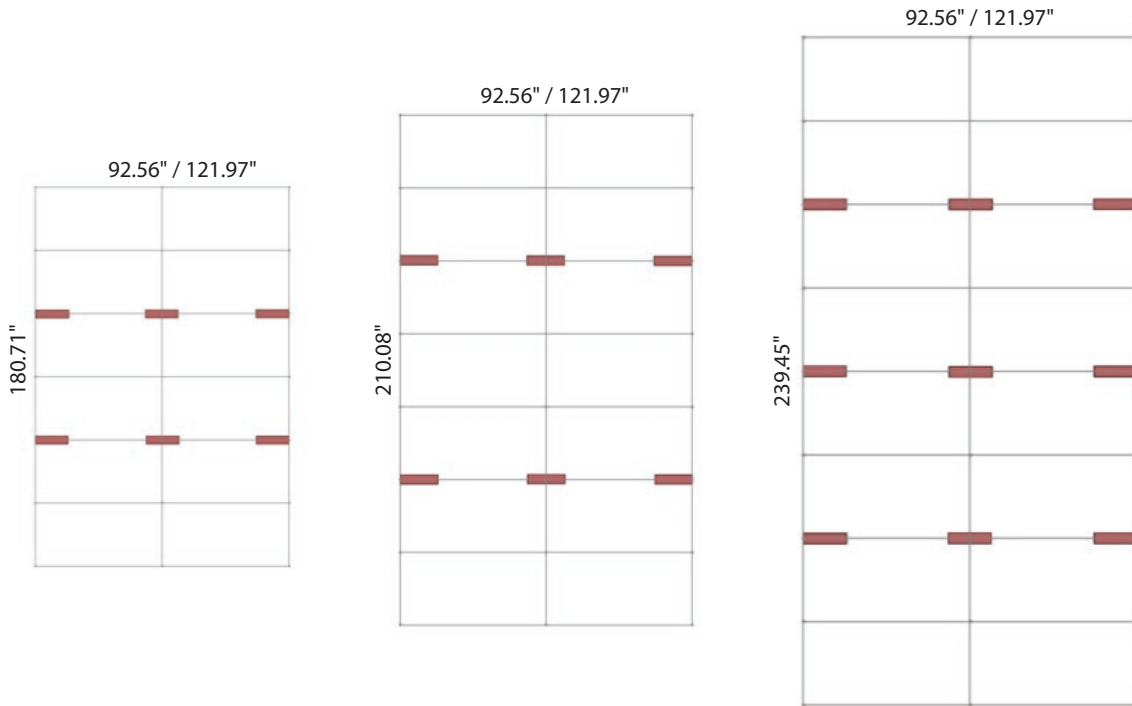

1. Push ridge from inside up by 0.59\"/>

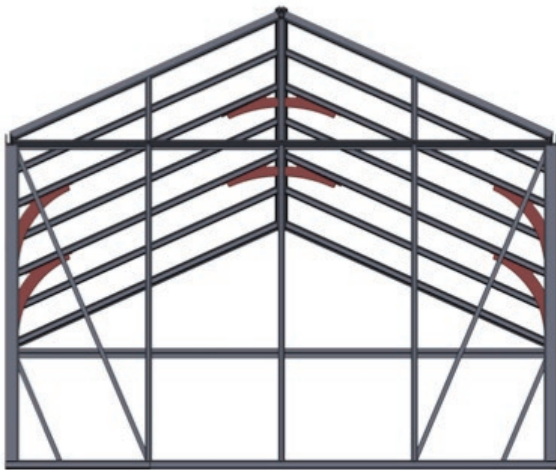

Not used for sizes L = 63.23\"/>

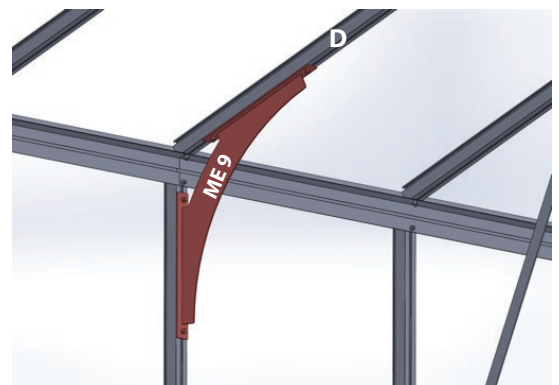
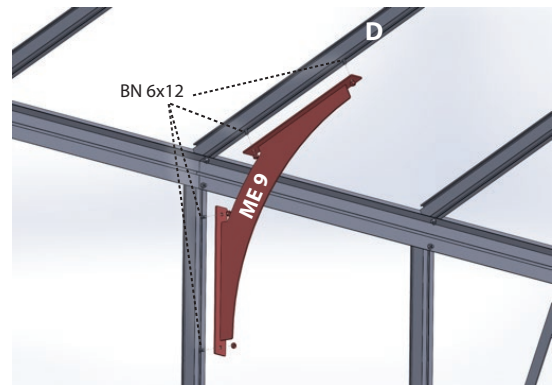

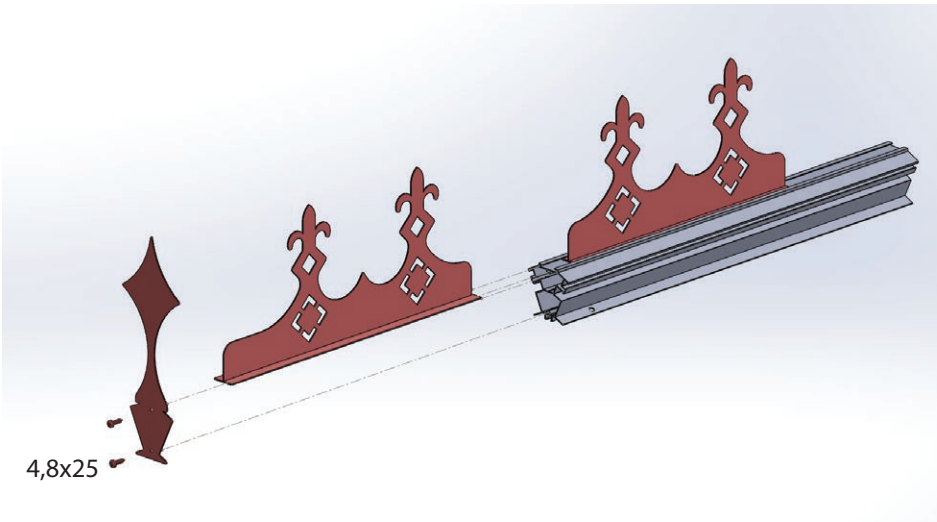
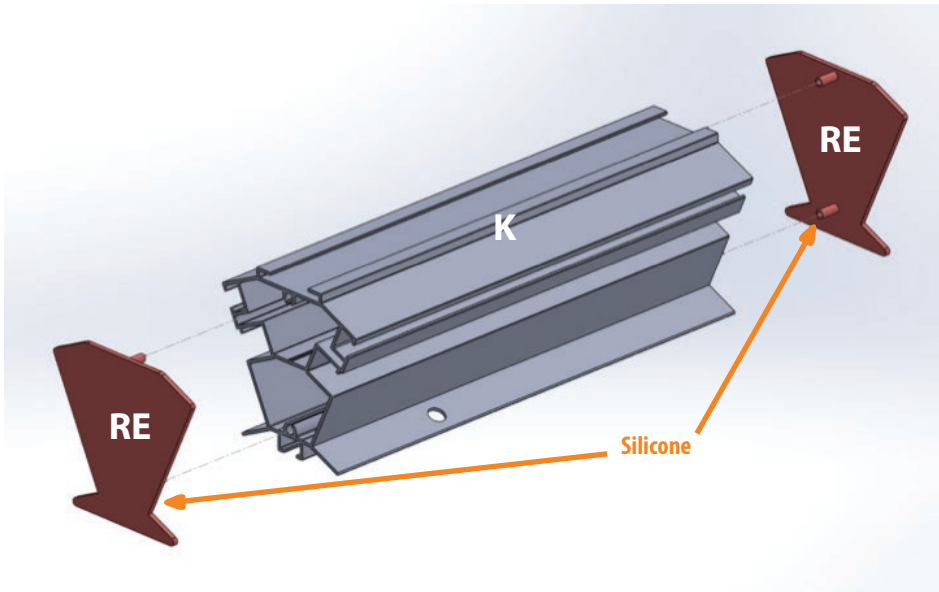

Install ridge decors before roof windows

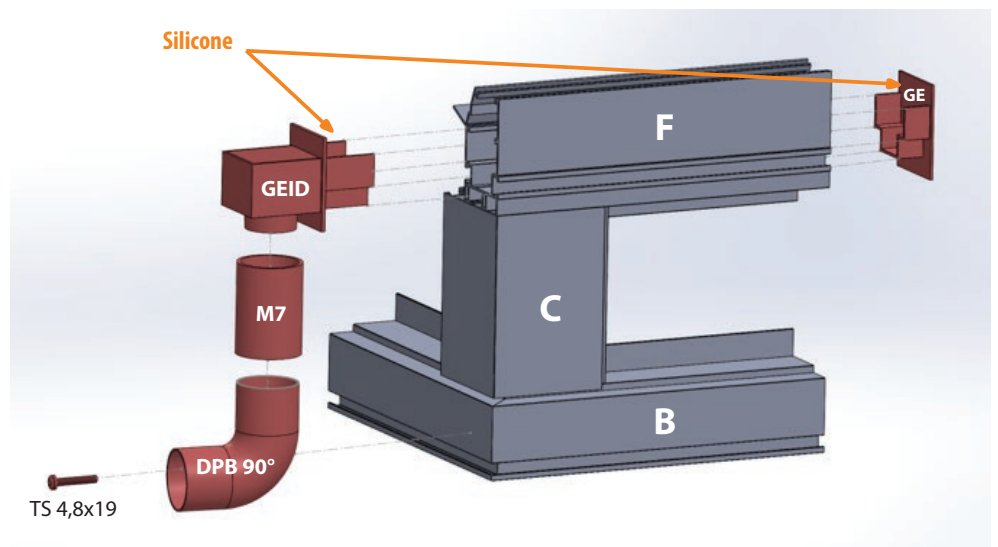
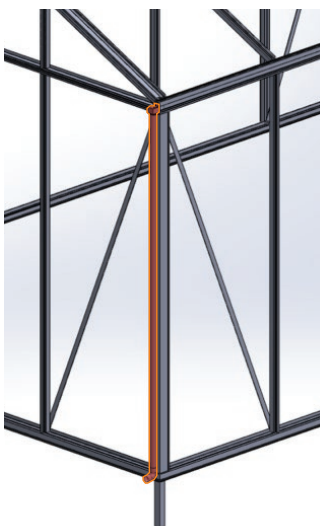

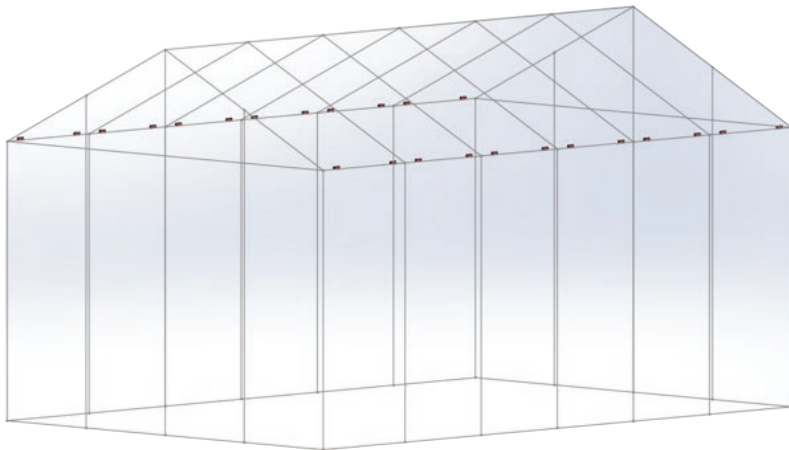
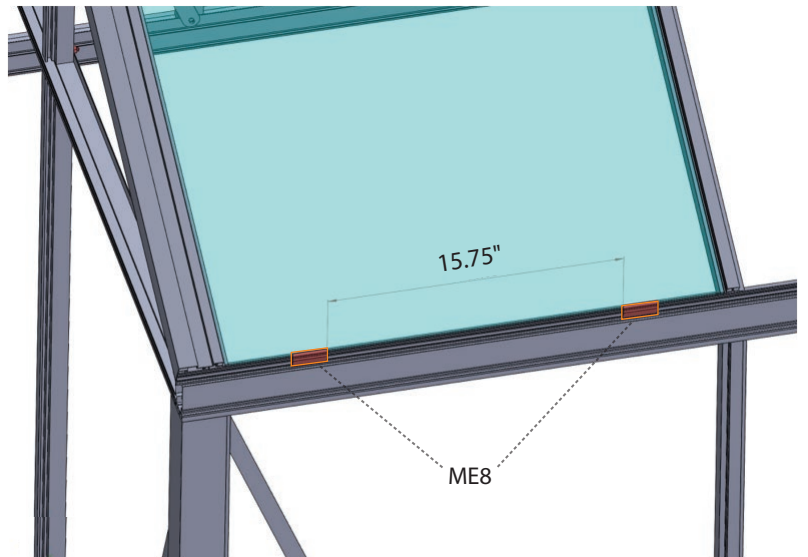
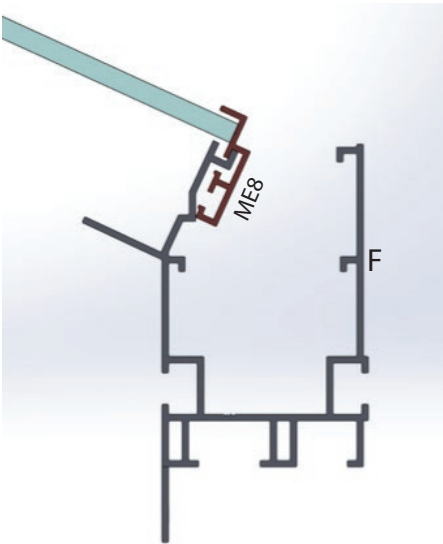
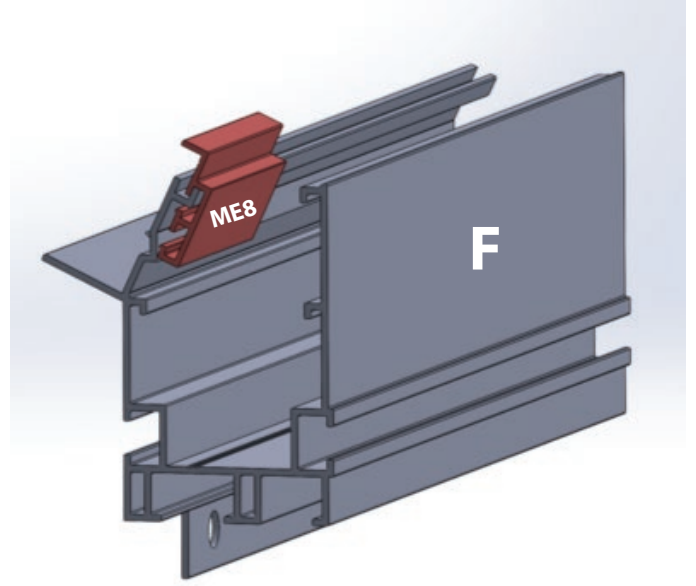
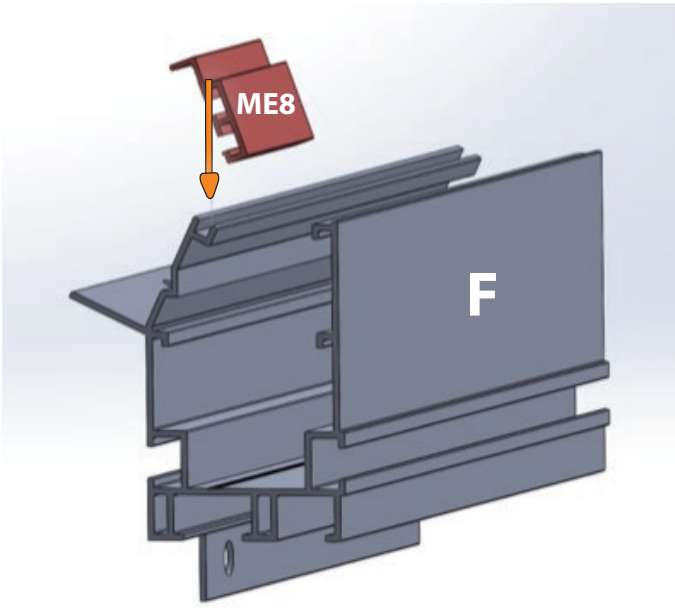

Glazing rubber install

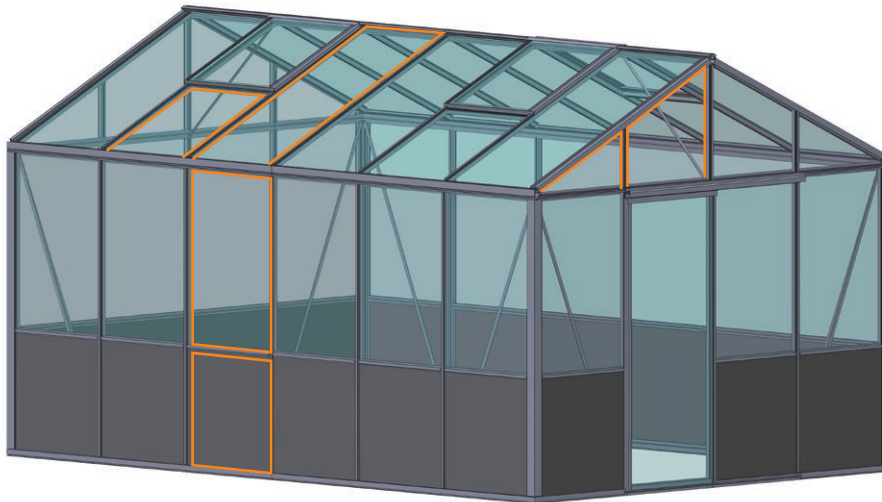
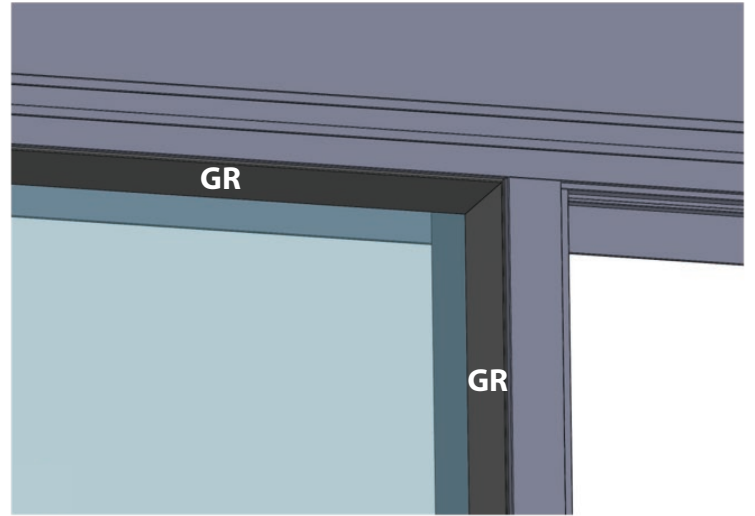
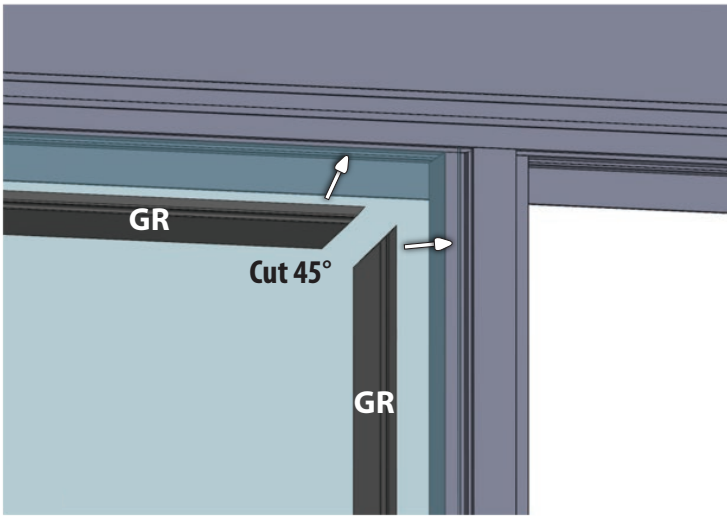
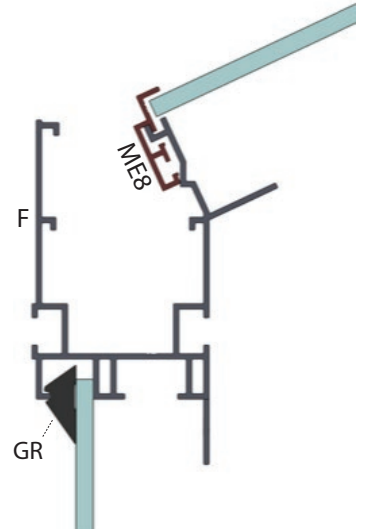
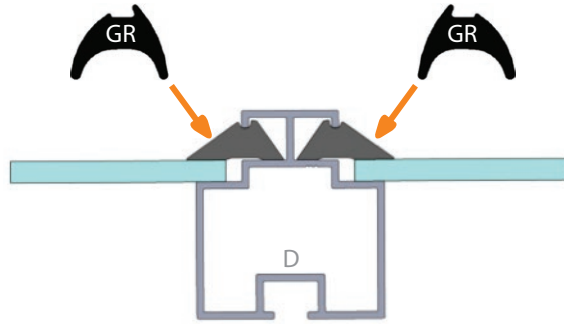
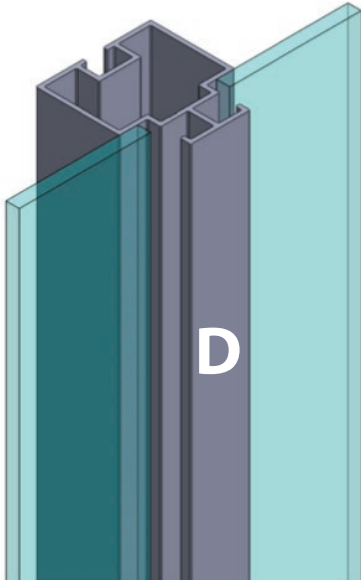

Rubber placement

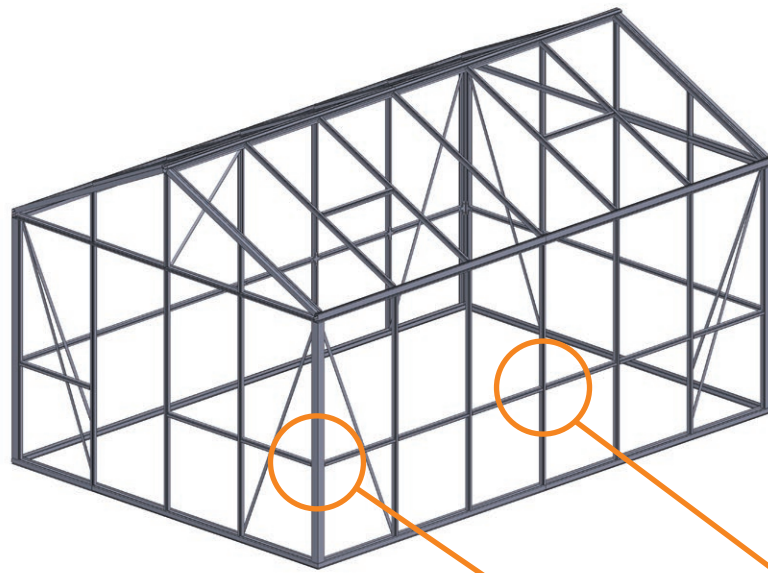

2x B6x12

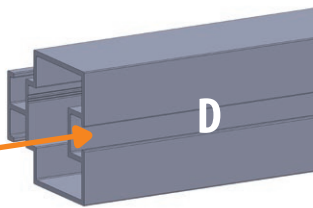

ME6 P

BN6x12

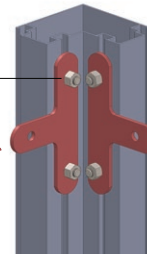

+2 B6x12

PC12

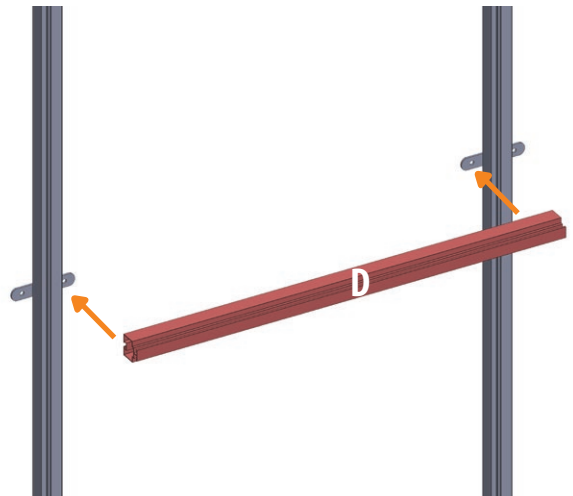
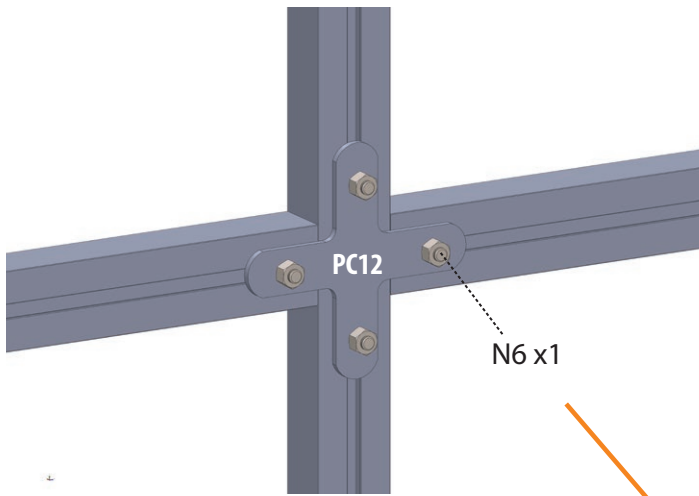
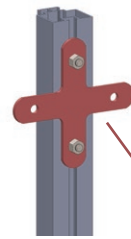

Let horizontal profile D move freely

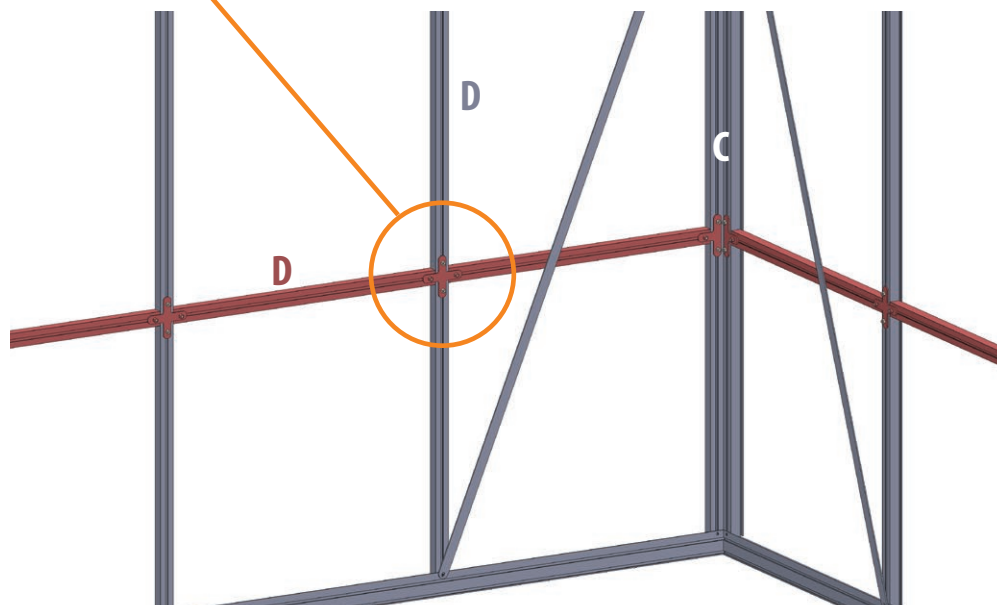

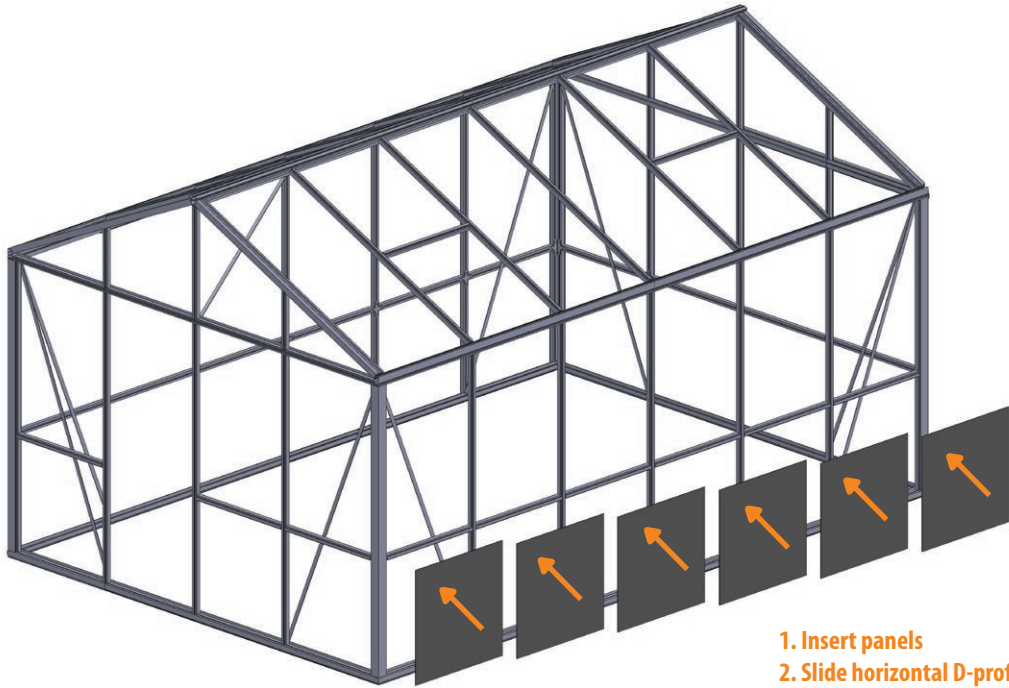

1. Insert panels
2. Slide horizontal D-profile onto panels
3. Tighten the screws
4. Insert glazing rubber

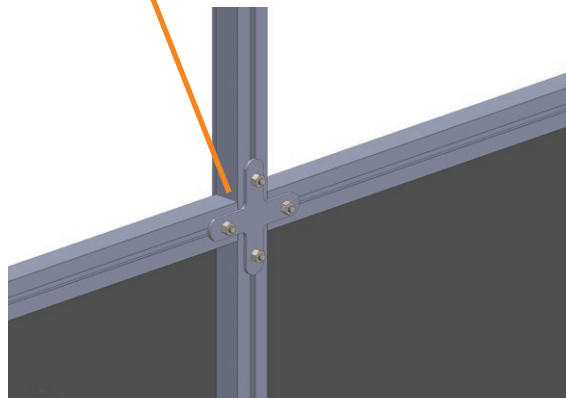
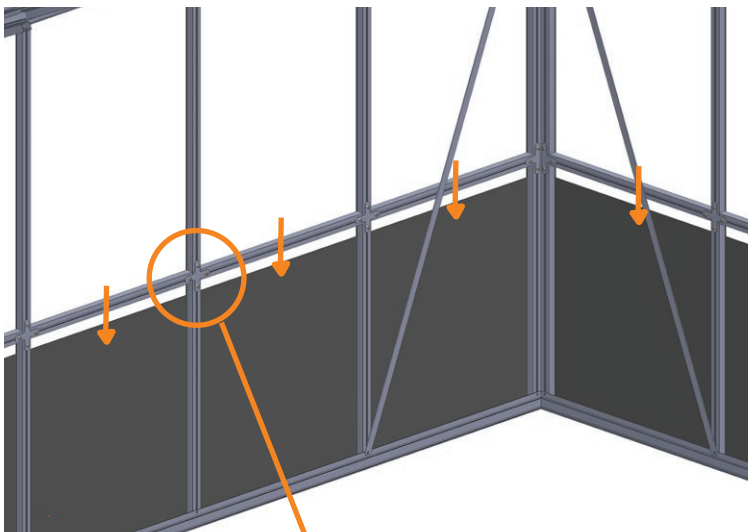

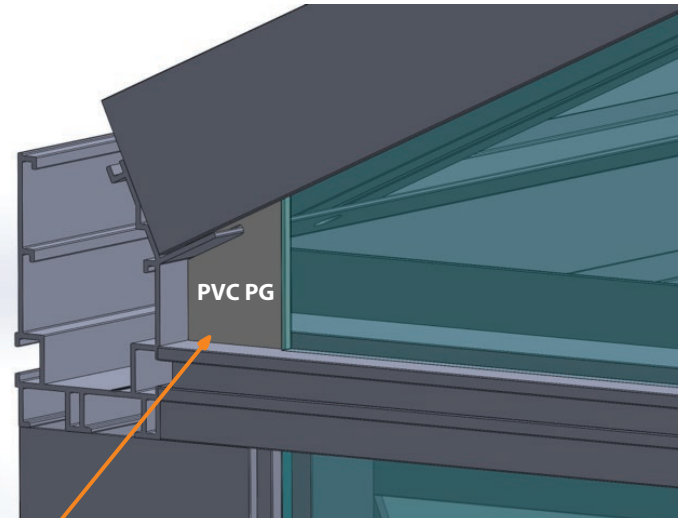
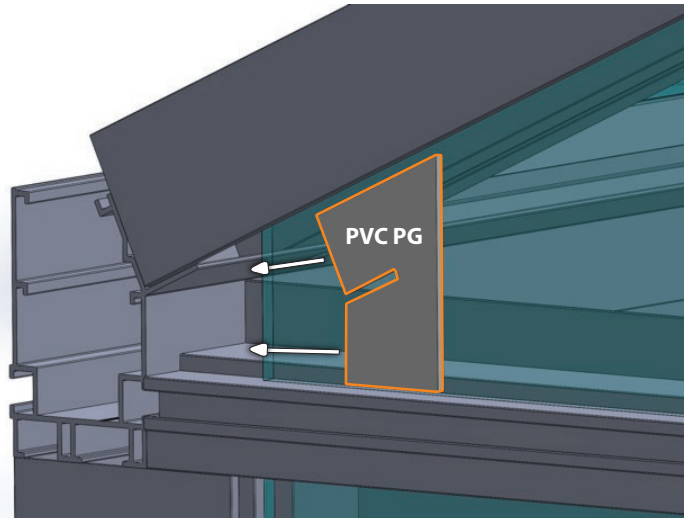
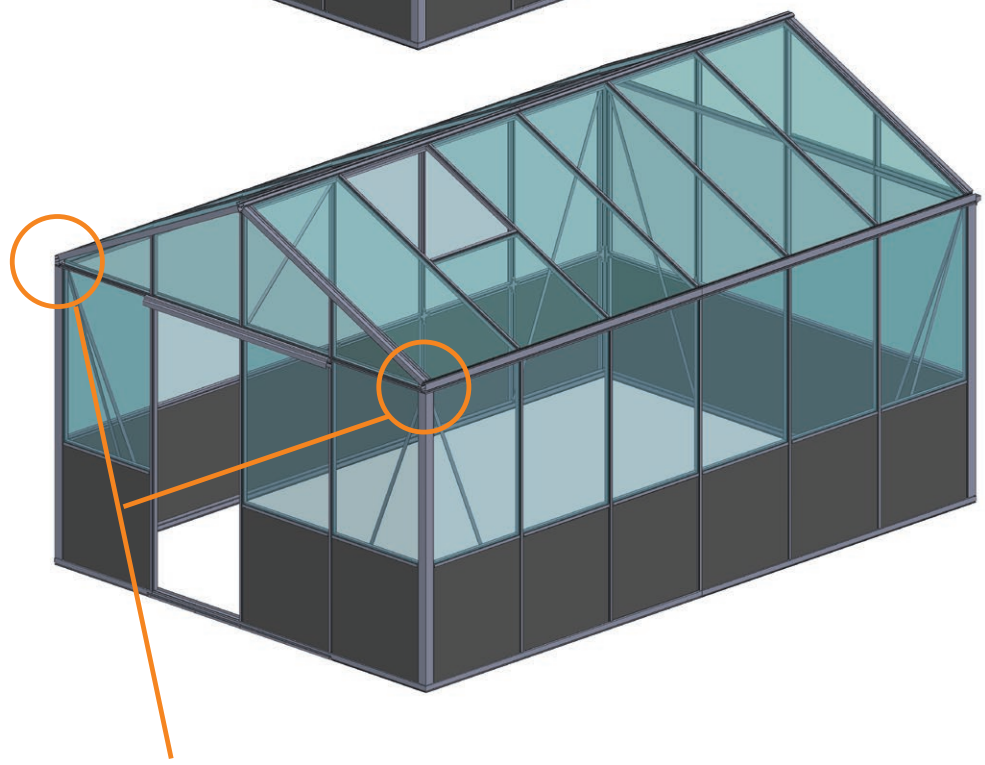
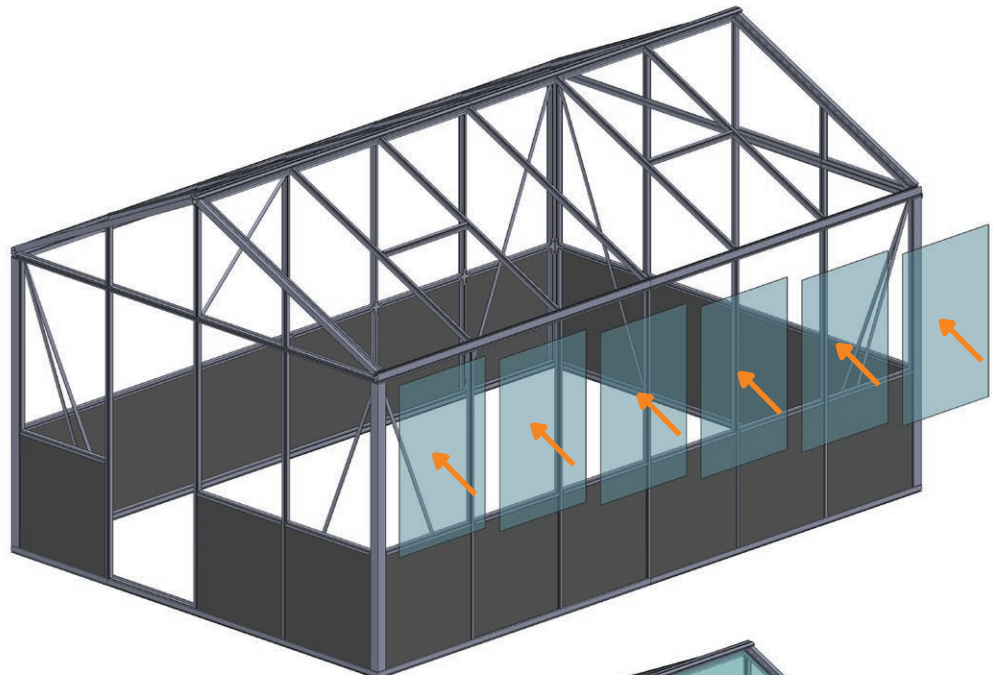

Silicone

Sliding doors

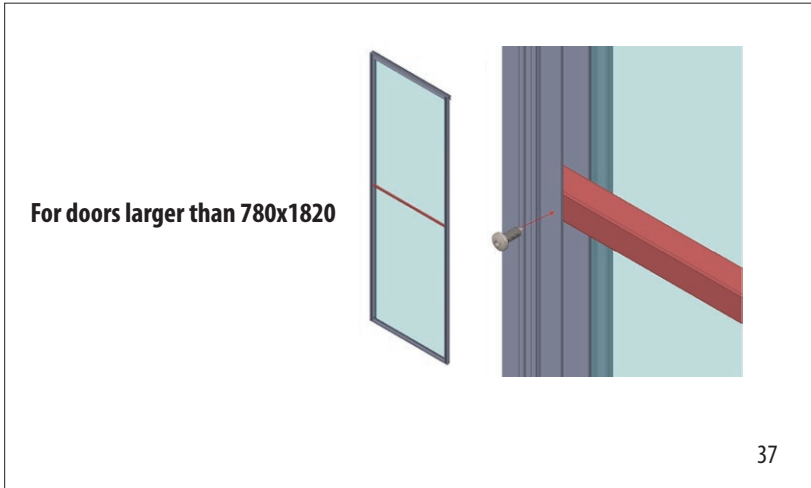
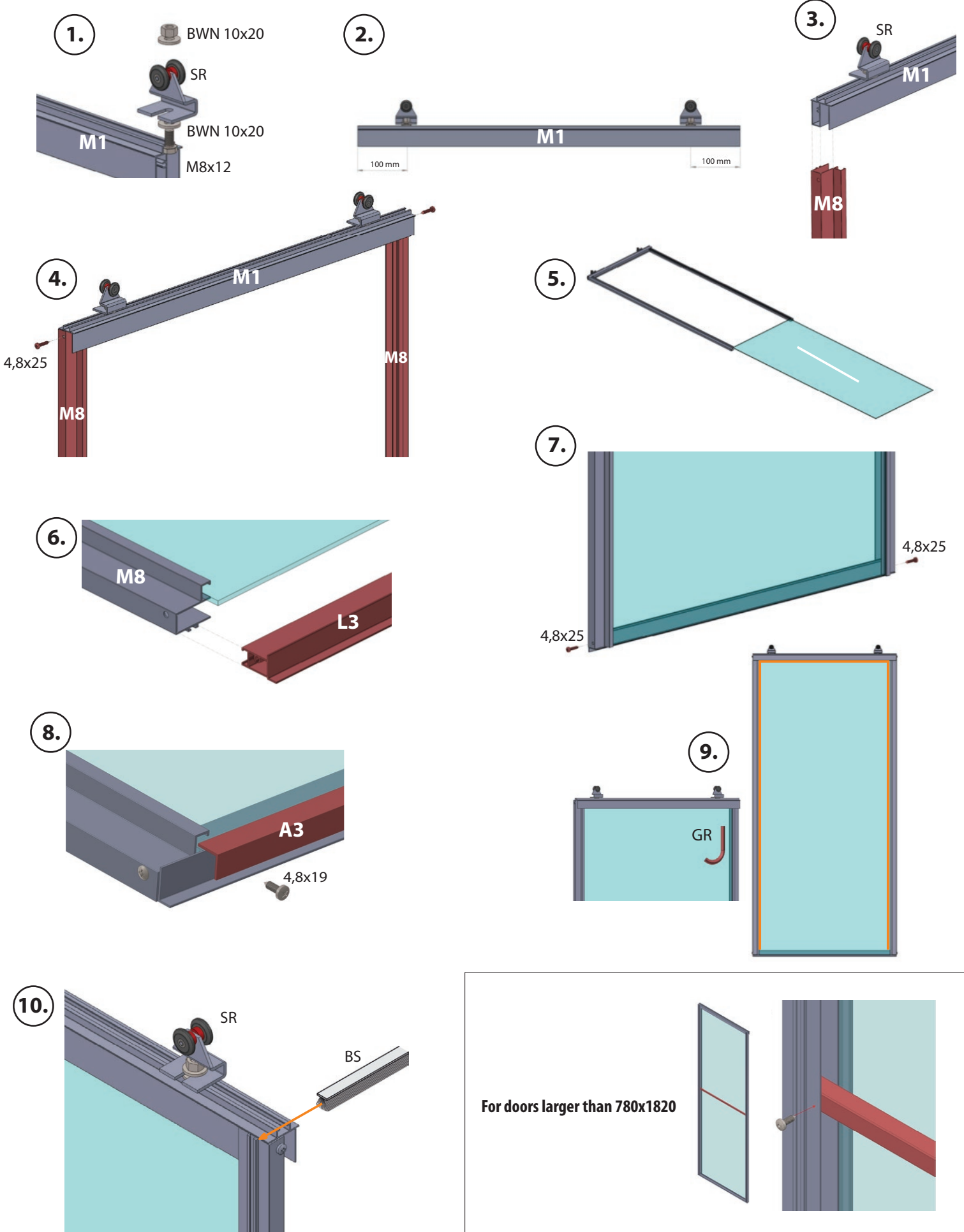

Roof window

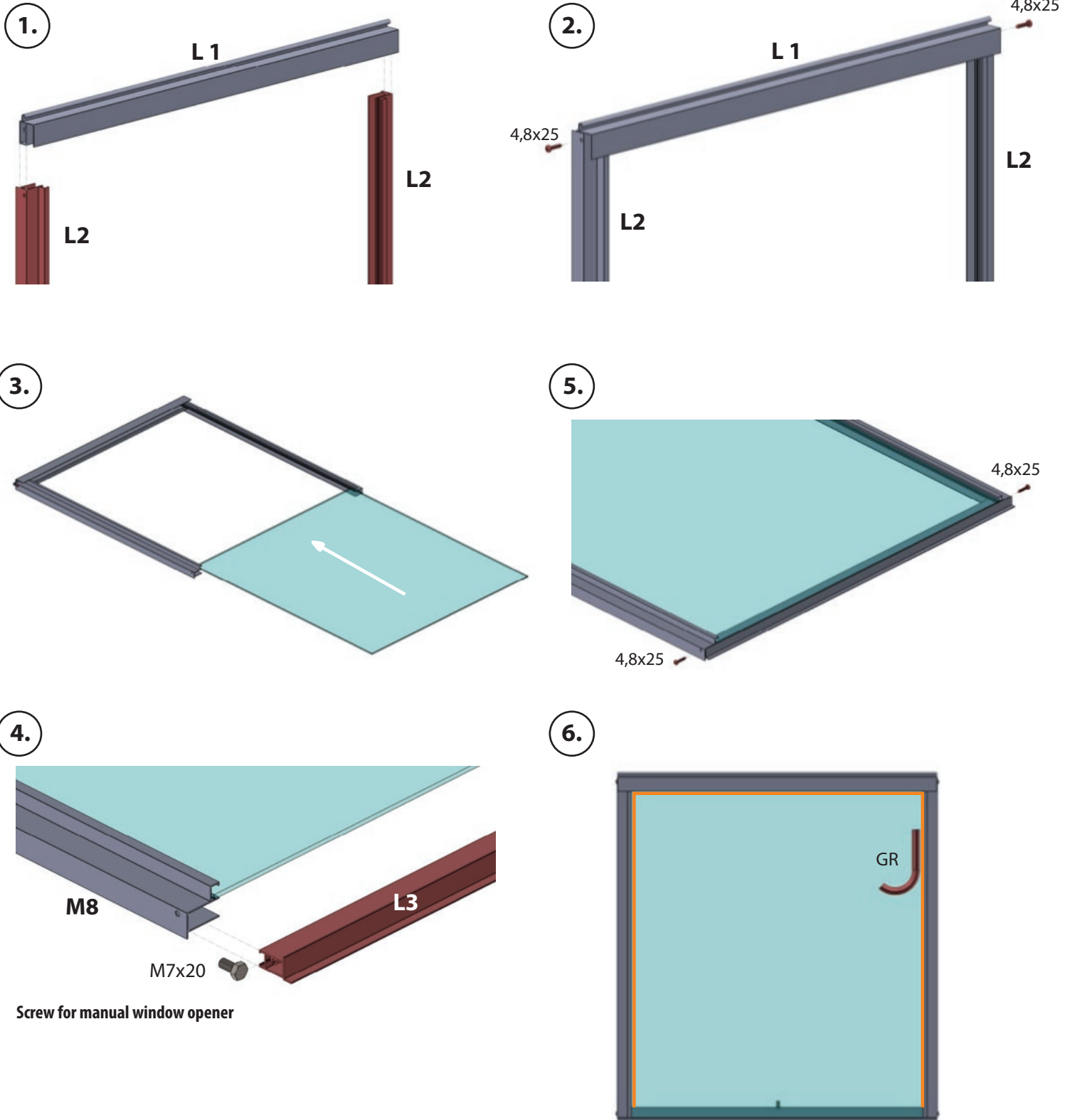

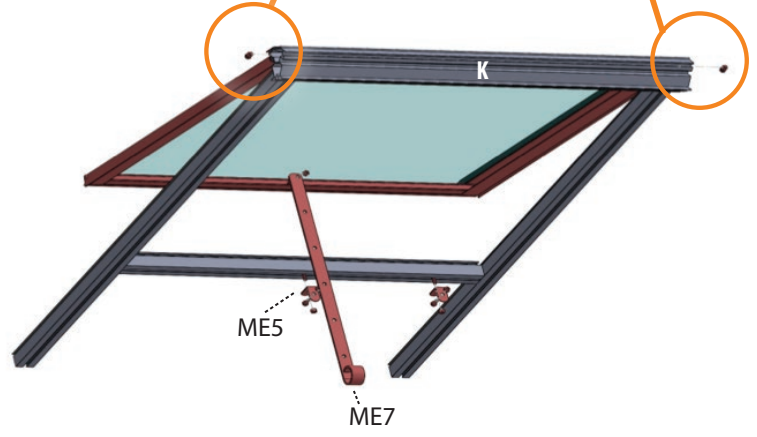
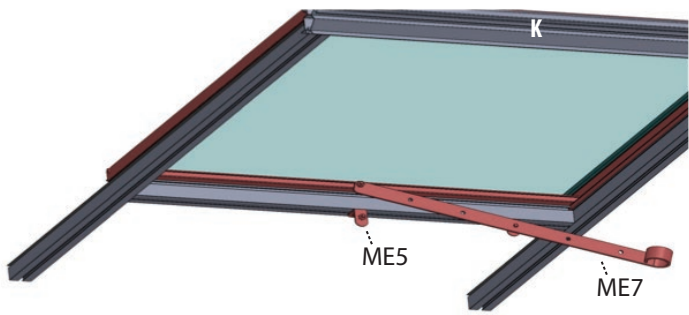
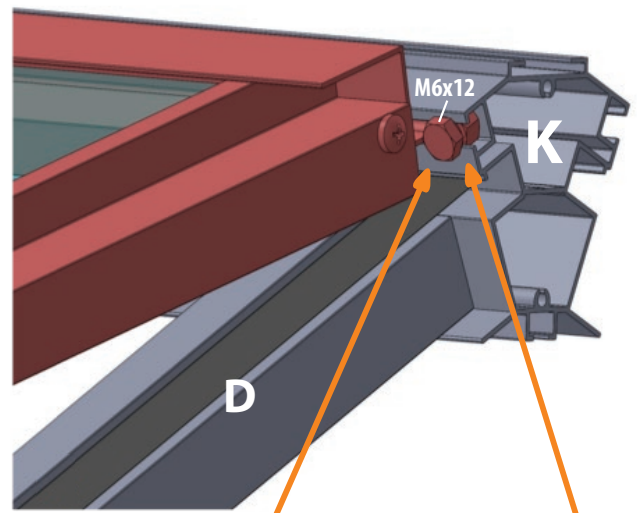
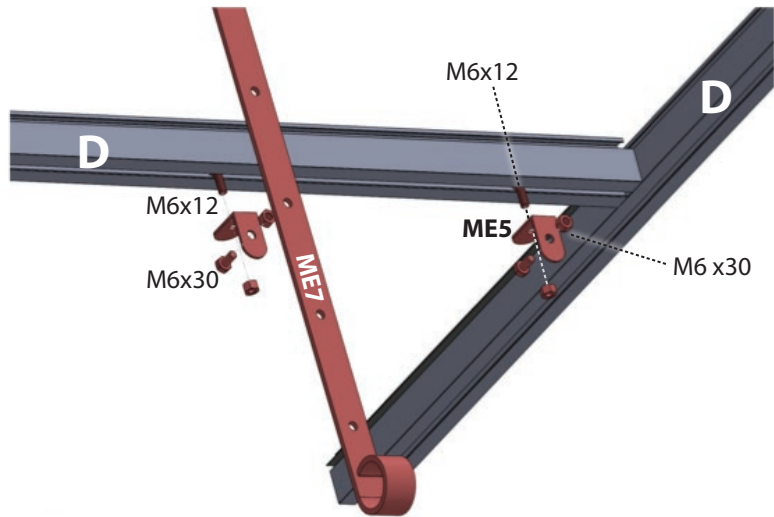

Sliding doors

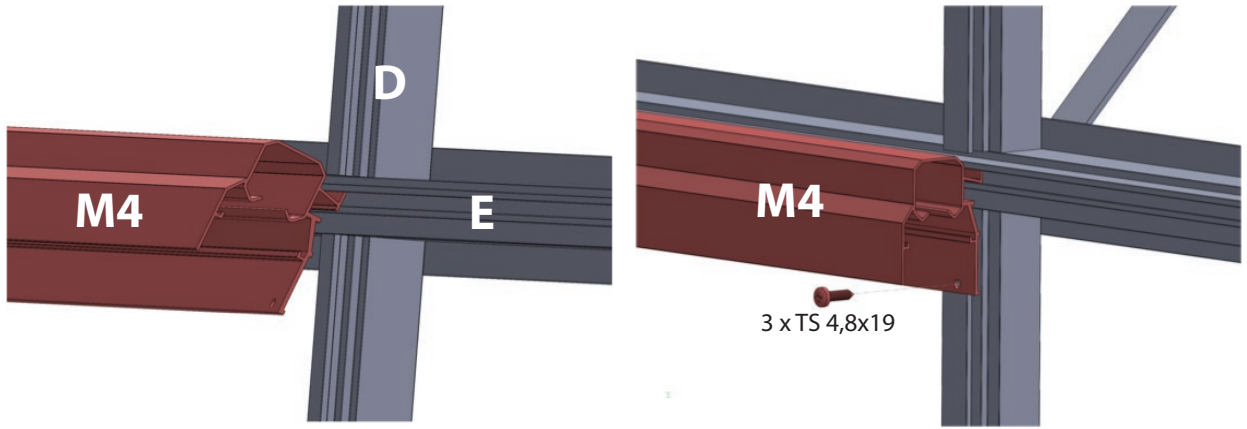

If in conflict with extension rod, cut out part here

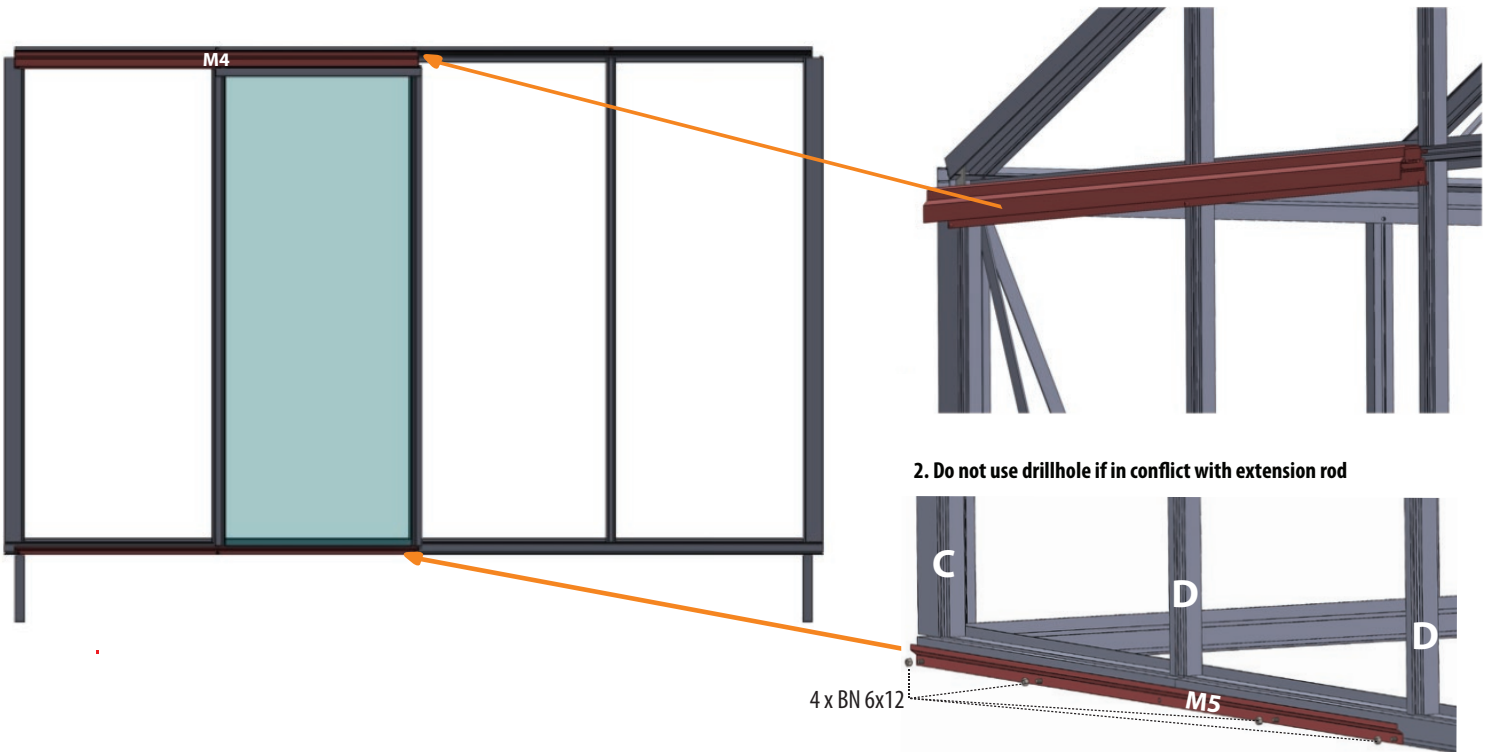
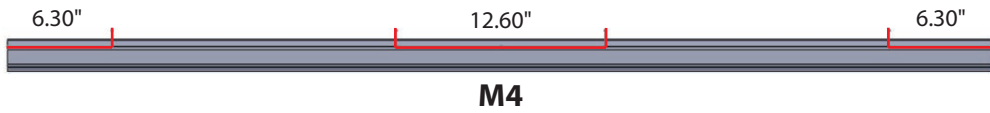

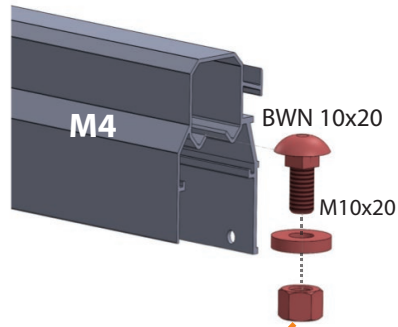
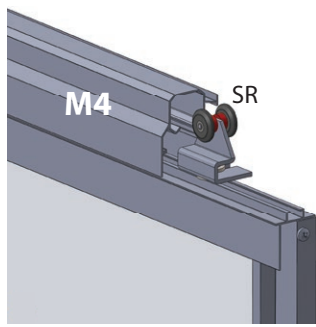

Insert doors into door profile and add stoppers

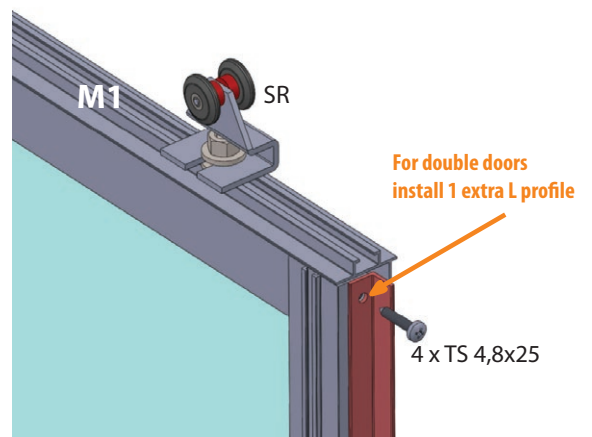
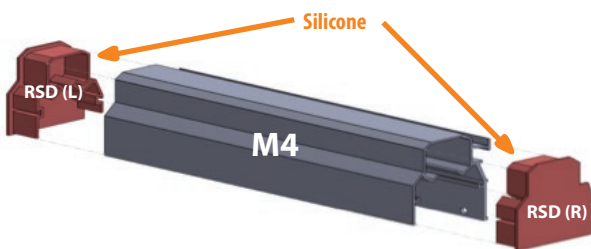
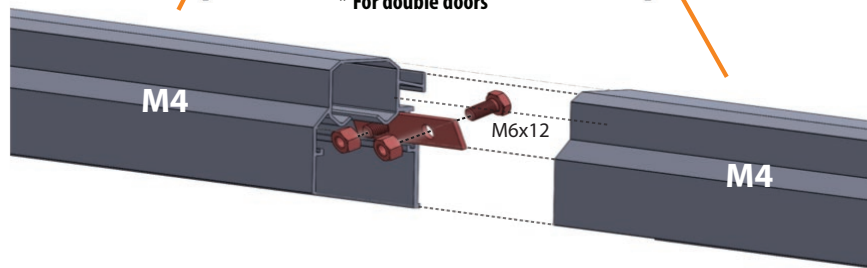
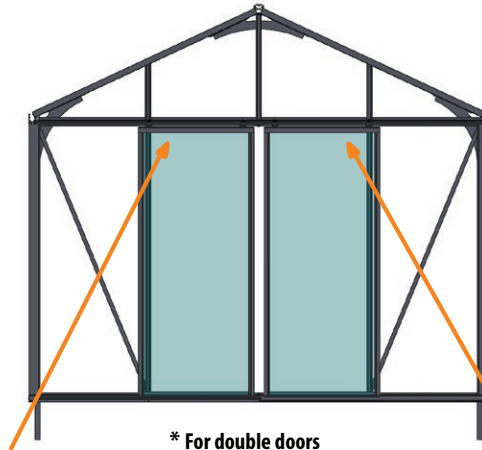
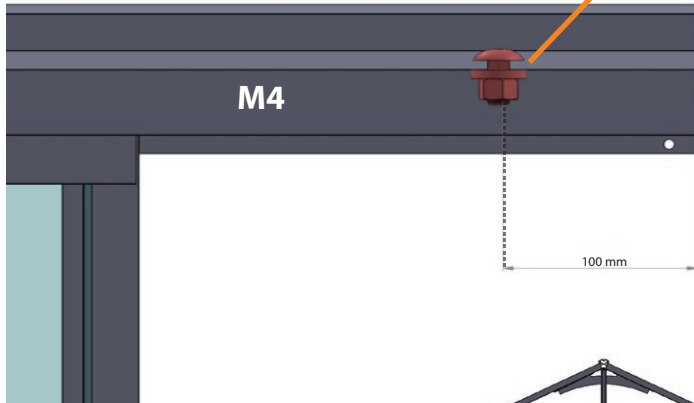

Window Crossbars (Optional)

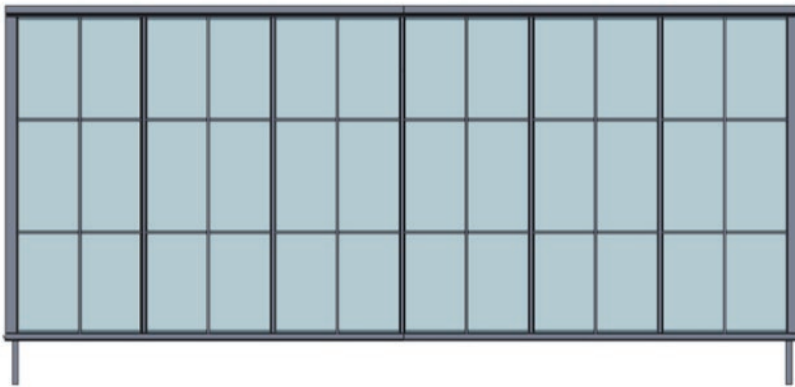
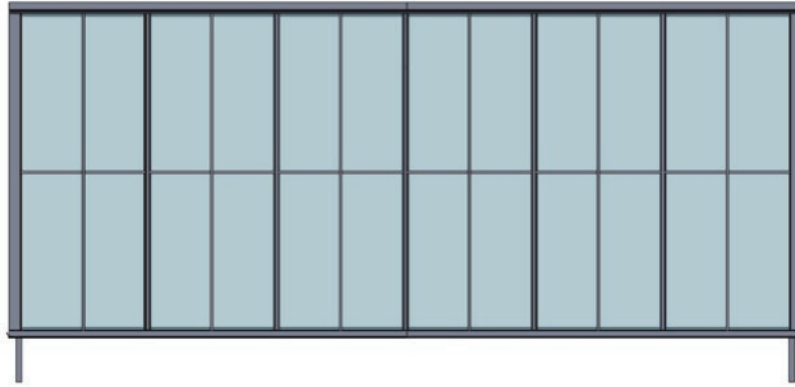

Glue to the window

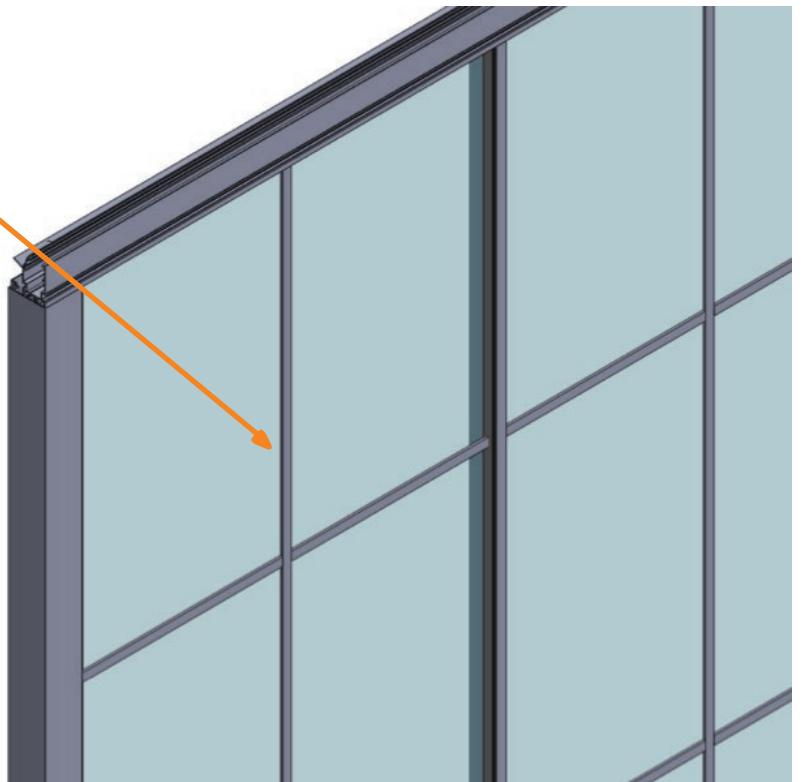

ACCESSORY MOUNTS

1. Insert the special screw into the profile

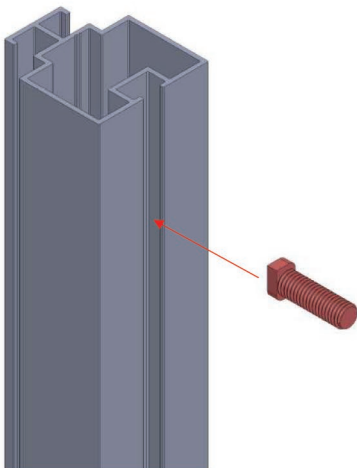

2. Turn it 90°

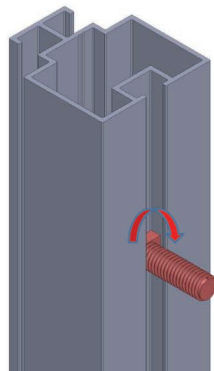

3. Attach the accessory and secure it with a nut

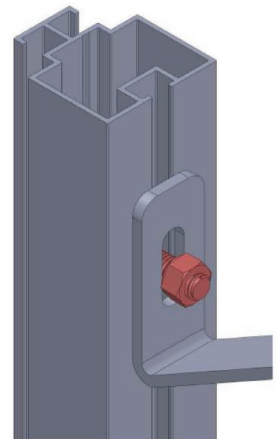

STORAGE ROOM WALL INSTALLATION (OPTIONAL)

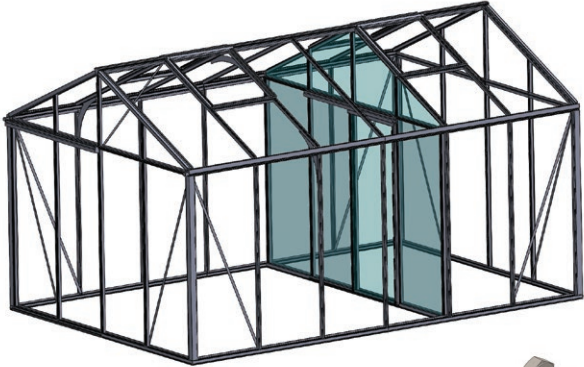

M6x12

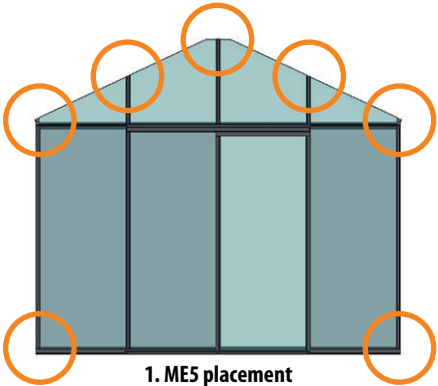
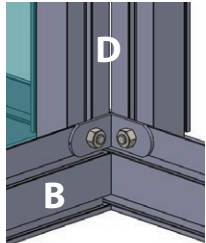
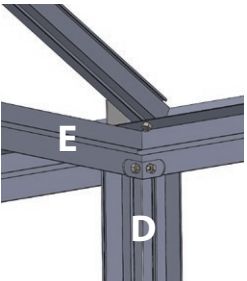
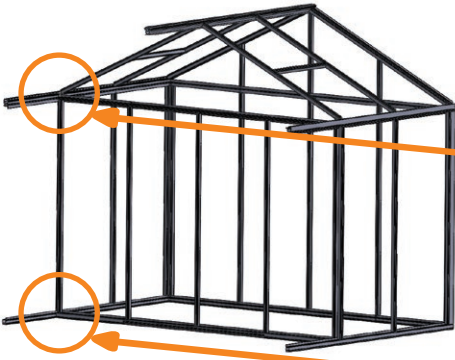

1. ME5 placement



2. For window installation see step 18

3. For doors installation see step 20 and 23/24

